

Click number attached to the part or the part numbers on the next pages to link to other parts, some parts may have no link

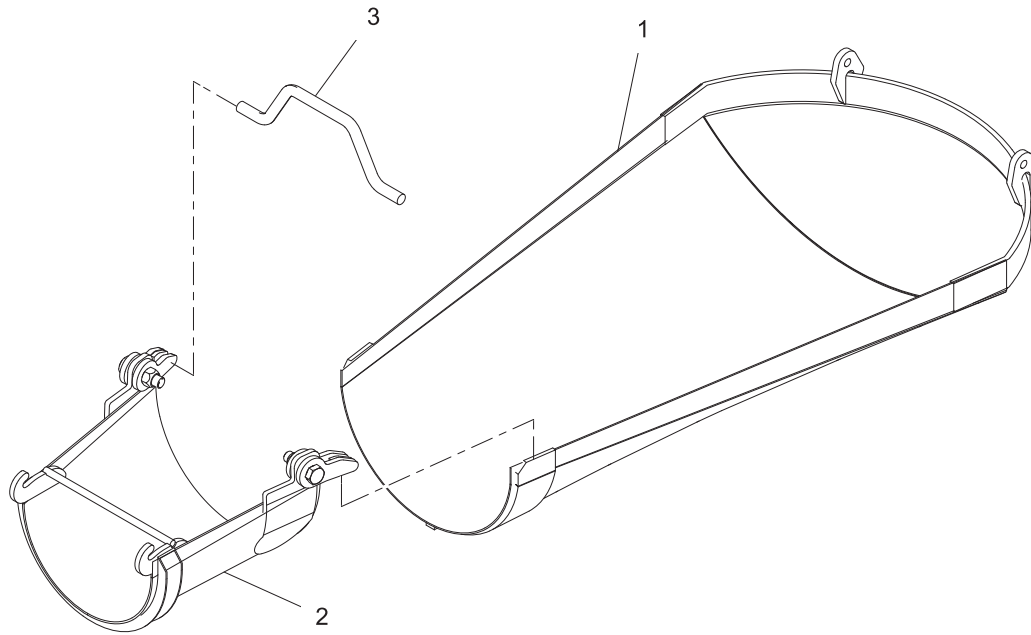

REF	PART NO.	DESCRIPTION	QTY	REF	PART NO.	DESCRIPTION	QTY
1	<a href="#">22848</a>	WDMT, Main Chute, 44", STD.....	1	3	<a href="#">30225</a>	BRKT, Support, Manual Main Chute...	1
2	<a href="#">33513</a>	WDMT, Chute Flip, Standard, 2012....	1	4*	<a href="#">19515</a>	Liner Main Chute - Weld IN.....	1
	<a href="#">33514</a>	WDMT, Chute, Flip, Paver, MY12.....	1	5*	<a href="#">20829</a>	Liner, Flip Chute - Weld IN - Paver .....	1

\* ITEMS 4 & 5 ARE NOT SHOWN IN THE ILLUSTRATION

WHEN ORDERING PARTS, SPECIFY MODEL NUMBER, SERIAL NUMBER AND DESCRIPTION OF PARTS REQUIRED

	<h2>MANUAL FLIP CHUTES</h2>	DATE: Released 01-2016	<b>GROUP</b>  <b>15</b>
		MODEL: FD	
		PAGE: 15.3	