

# Marmon-Herrington

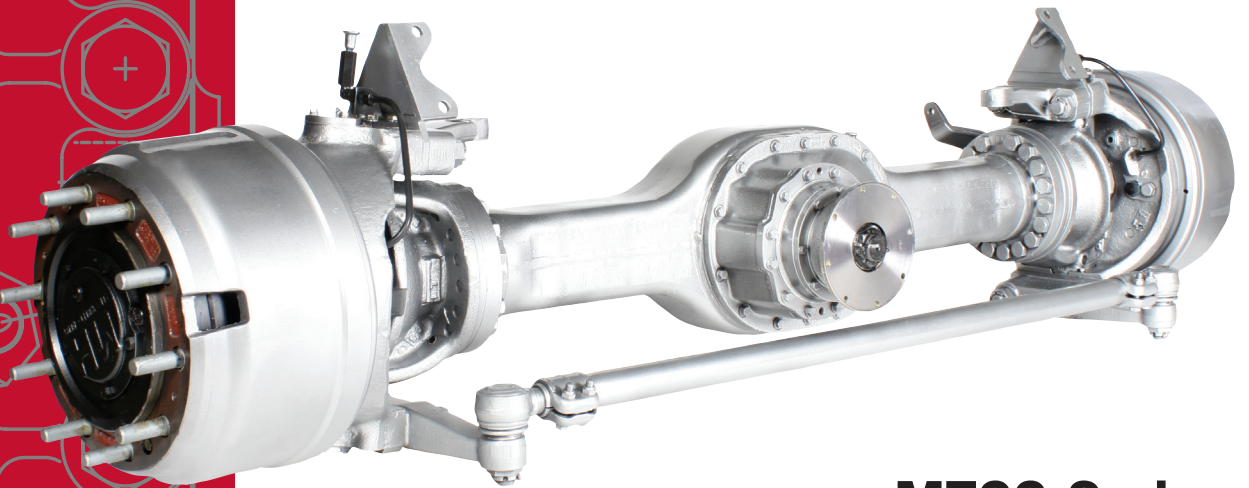

**MT22 Series**  
**Parts Manual**

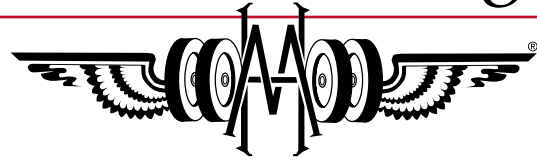

# TABLE OF CONTENTS

## FORWARD

WARRANTY POLICY AND PROCEDURE .....	3-5
-------------------------------------	-----

## MT22/R/N/H AXLE

DIFFERENTIAL CARRIER HOUSING MT22/R/N/H .....	6-7
DIFFERENTIAL MT22/R/N/H .....	8-9
DIFFERENTIAL CARRIER HOUSING MTL22 .....	10-11
DIFFERENTIAL MTL22 .....	12-13
DIFFERENTIAL LOCK AIR CHAMBER MTL22 .....	14-15
AXLE HOUSING MT22/R/N/H .....	16-17
AXLE SHAFT ASSEMBLY MT22/R/N/H .....	18-19
PLANETARY MT22/R/N/H .....	20-21
WHEEL HUB, BRAKE DRUM MT22/R/N/H .....	22-23
BRAKE MT22/R/N/H .....	24-25
TIE-ROD MT22/R/N/H .....	26-27

Marmon-Herrington

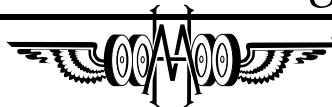

13001 Magisterial Drive • Louisville, KY 40223  
(502) 253-0277 • (800) 227-0727 • Fax (502) 253-0317  
E-mail: [info@marmon-herrington.com](mailto:info@marmon-herrington.com)  
[www.marmon-herrington.com](http://www.marmon-herrington.com)



# FORWARD

## GENERAL

This manual has been prepared for operators and service personnel working with the Marmon-Herrington series of transfer cases and front drive axles. For further technical assistance, please contact Marmon-Herrington Customer Service.

Please observe and follow all procedural and maintenance guidelines to ensure reliable operation and optimum service life. The Marmon-Herrington basic service schedule will integrate seamlessly with most preventative maintenance programs.

Marmon-Herrington shall not be liable for component failures or damages caused by operational abuse or neglect. Please review the Warranty Statement for a detailed explanation of coverage and claim reporting procedures.

We thank you for your investment in Marmon-Herrington equipment, and look forward to serving your needs in the best tradition of engineering excellence.

## MISCELLANEOUS ISSUES

Marmon-Herrington equipped vehicles are designed for "as needed" AWD operation only, in off-road conditions.

Due to issues associated with torque, drive line wind-up and ratio mis-match, Marmon-Herrington axles and transfer cases must never be operated in AWD mode or while engaged on hard, dry surfaces.

Owner/Operators should seek expert assistance when considering alternative gear ratios and/or tire sizes.

Marmon-Herrington Axles and Transfer Cases should only be shifted when at a full stop. "Shifting on the Fly" or shifting while in motion are prohibited modes of operation. This applies to front axle engagement, high and low transfer case ranges, and locking differentials. The only exceptions are those vehicles equipped with Marmon-Herrington's **SAFE-T-SHIFT system**.

## SAFE-T-SHIFT

In 2003, Marmon-Herrington developed an electronic management system to help prevent "shift on the fly" damage. It consists of a microprocessor that receives speed information from a remote sensor in the transfer case. The system is calibrated to activate the shift solenoids at the first detection of motion, and then cancel control functions at 4 mph.

Relative rotation speeds of the gear sets may require that the vehicle be rolled a few feet before the shift will complete.

Axle and transfer case shifting can generally be heard and felt inside the cab. Indicator lights on the dash will also illuminate when the shift is complete. **DO NOT ACCELERATE UNTIL APPROPRIATE POSITION IS INDICATED ON DASH LIGHT OR CONTROL SWITCH.**

### Shift Procedure

1. With the vehicle at a complete stop, select the desired range or front axle position.
2. Place the main transmission in gear.
3. Allow the vehicle to idle forward (or backwards) at walking speed until shift is completed.
4. Verify proper position indication.
5. Accelerate normally.

In the case of a manual transmission, ease the clutch out in low gear, allowing the vehicle to "walk" until shift is completed.

Some possible exclusions to the Safe-T-Shift program are those vehicles fitted with a transfer case mounted PTO, OEM factory installations, and any with non-Marmon-Herrington transfer cases.

# Marmon-Herrington

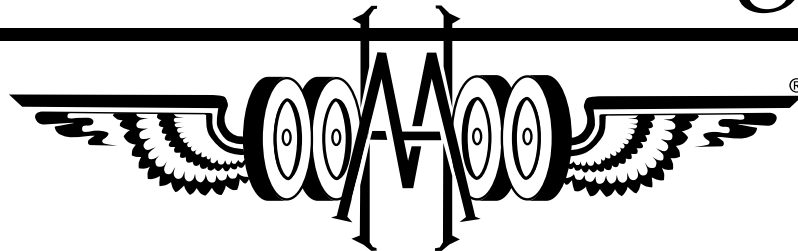

## MARMON-HERRINGTON WARRANTY

This is to certify that we, Marmon-Herrington Company, Louisville, Kentucky, warrant each new chassis remanufactured, or assembly or part furnished for the remanufacture of a truck chassis against defects in material and workmanship under normal use and service. Marmon-Herrington's obligation under this warranty is limited to replacement of, at our factory, any part or parts thereof which shall, within one (1) year after delivery of such vehicle to the final user after installation of the all-wheel drive installation kit, be returned to us with transportation charges prepaid, and which our examination shall disclose to our satisfaction to have been thus defective.

Marmon-Herrington will warrant covered components against defects in material and workmanship under normal use and service for the specified period. This warranty includes all internal components with the following exceptions: Exceptions include, but are not limited to wear items such as brake linings and drums, oil seals and bearings, which will be covered for a period of 12 months or 12,000 miles, whichever ever occurs first.

Failure to follow designated maintenance procedures and schedules, maintain required lubrication levels, or any form of operational abuse or misuse will void all warranty coverage expressed or implied.

Failure reporting and claims submission procedures are to be followed as outlined in the standard warranty guidelines

Service parts are manufactured to the same standards as production installed parts. However, since the installation thereof, as well as the age and condition of the receiving vehicle are beyond the control of Marmon-Herrington, Service Parts are warranted for a period of ninety (90) days or five thousand (5,000) miles whichever first occurs. All other regular warranty conditions apply.

On vehicles operating OVERSEAS, the determination of defects will be made at Marmon-Herrington Company, Louisville, Kentucky, from complete information supplied in writing by overseas distributors or recognized acting distributors. Complete information is defined to mean: vehicle serial number, user's name, date of delivery, mileage at time of breakage, date of breakage, type of service, nature of break or fault, distributor's recommendation (for our guidance only), and any other pertinent information. After determination of our obligation, any parts to be replaced will be shipped to distributor or acting distributor in accordance with his instructions.

This warranty is in lieu of all other warranties expressed or implied and of all other obligations or liabilities incurred by Marmon-Herrington. Marmon-Herrington neither assumes nor authorizes any other person to assume any other liability in connection with this sale, including but not limited to indirect or consequential damages.

This warranty shall not apply to any vehicle which shall have been repaired or altered in any way so as in our judgment, to affect its stability or reliability, nor which has been subject to misuse, negligence, or accident, nor which shall have been operated at a speed exceeding the factory rated speed or loaded beyond the factory rated load capacity or operated in violation of Marmon-Herrington's instructions.

Marmon-Herrington makes no warranty whatever on components of the original manufacturer's chassis not related

to the modification work. Also, no warranty is made on tires, rims, ignitions, or other parts usually warranted separately by their respective manufacturers.

The manufacturers reserve the right to make changes in design, and changes or improvements upon their product, without notice, and without incurring any obligation to install such changes or improvements upon their products theretofore manufactured.

This warranty shall become effective only when the Warranty Certificate has been returned to Marmon-Herrington and validated by the same.

In the case of vehicles operating in extreme conditions such as corrosive material mines, deep- water zones or areas of hostile aggression, the following warranty limitations apply:

Marmon-Herrington shall not be responsible for damage caused by chemical corrosion, internal water damage due to total immersion, or explosive impact. These conditions constitute severe duty and are not covered by Marmon-Herrington standard warranty.

## WARRANTY REPAIR AND CLAIM PROCEDURE

### Initial Failure Reporting

1. Operator must call Marmon-Herrington Customer Service prior to performing any repairs and receive a Repair Authorization Number to be eligible for reimbursement. The work authorization number does not guarantee payment but is an acknowledgement that the vehicle is within the warranty period in terms of date and mileage, and that a claim has been activated. **It will be the responsibility of the operator to ensure that their repair facility is aware of, and complies with, the guidelines of this policy.**
2. To expedite the authorization process, you will need the Sales Order Number or "S" number found on the component I.D. tag. You will also need the Vehicle Identification Number or the last six digits of the "VIN", the date the vehicle was placed in service, and the current mileage. Please note the following:
  - This Warranty Registration should have been submitted at the time of delivery. If our records do not include a warranty registration, you must complete one before any authorization for repair can be issued. We will make them available by mail or fax upon request.
3. Marmon-Herrington will pre-approve .5 hours diagnosis/inspection time prior to your call for repair authorization. If the the diagnosis/inspection complaint does not reveal a warrantable failure, or result in a warrantable repair, the customer will be responsible for all charges including diagnosis/inspection time.
4. The Operators Manual contains information covering proper equipment use and maintenance schedules. Operators must adhere to these guidelines to be eligible for reimbursement, and service records must be provided upon request.

### Pre-Repair Requirements

1. Authorization for repairs will require a written estimate/repair order of costs after determination that a warrantable condition is found to exist.

- Estimates must contain the following information:
  - A list of all parts necessary for specific job and if applicable, all parts that will be invoiced back to Marmon-Herrington.
  - The cost of disassembly, inspection and diagnosis of any portion of the vehicle to determine extent of repairs needed.
  - Current labor costs, reflecting both hourly rate and number of hours to effect repairs must be listed.
  - Miscellaneous charges such as “shop supplies” must be defined. Actual dollar amounts must be listed, as percentages will not be accepted.
  - Sublet repairs must also be defined and included in the estimate at their actual dollar amount.
  - NOTE: If it becomes necessary to exceed the original estimate in terms of parts or labor, the repair facility must call Marmon-Herrington Customer Service for additional authorization.
- Only the use of Marmon-Herrington supplied parts will constitute reimbursement unless prior approval has been obtained.

### Parts Ordering

While Marmon-Herrington operates a full Service Parts Department, replacement parts needed to effect Warranty repairs must be acquired through Customer Service to be eligible for reimbursement.

### Post Repair Requirements

The final invoice or work order must include the following:

- Customer’s name, address, and phone number.
- The Vehicle Identification number.
- The Sales Order Number or “S” number, which the customer can provide or can be located on the I.D. tag, fixed to the transfer case or axle.
- The Axle or Transfer Case Model and Serial Number, also located on the I.D. tag.
- Mileage In / Mileage Out.
- The Cause and Correction of the repair including detailed description of repairs and parts replaced.
- The date the repair order was open and the date the repairs were completed.
- The Work Authorization Number obtained from Customer Service.

### Notes to Repair Facilities

- Miscellaneous charges such as “shop supplies” must be listed as separate line items and shown on the final invoice as stated in “Pre-Repair Requirements.” Invoices for sublet repairs must be made available upon request.
- All repairs must comply with any or all state and DOT requirements.
- Downtime of vehicle and incurred costs associated due to the delay of parts shipments or any other condition beyond our control is not reimbursable and should not be listed on the invoice.
- All failed parts that are required to be returned to Marmon-Herrington must be received before payment will be made. The Return Authorization will be sent with the replacement parts when shipped from Marmon-Herrington.
- All Claims must be submitted within 60 days of completion of repairs to be eligible for reimbursement.

For Work Authorization call: (800) 227-0727, Ext. 282  
 To Submit Claims by Fax: (502) 253-0317

Submit Claims by Mail to:  
 Marmon-Herrington Company, Customer Service Department,  
 13001 Magisterial Drive, Louisville, KY 40223.

### REPLACEMENT PARTS

When ordering replacement parts for **MARMON-HERRINGTON** installations, the following information should be given:

- FACTORY ORDER NUMBER** (found on I.D. Plate or small plate affixed to axle housing). This will be a six (6) digit number. (See illustrations this page.)
- Component for which parts are required, i.e. front drive axle or transfer case/drop box.
- Model of axle and/or transfer case/drop box, i.e. MT10, MVG 750, MDB500.
- Give quantity and part number required. **NOTE:** Drivelines, shift linkage, etc., can be found on the computer printout of Bill of Material, which is included in the Service Manual.
- Give complete billing and shipping address.

### CALL IN PROCEDURE

Before proceeding with repairs or ordering parts that you feel may be covered under warranty, you must first contact Marmon-Herrington Customer Service Department to obtain a Repair Authorization Number.

(800) 227-0727, Ext. 282      8am-5pm EST  
 (502) 693-1129                      5pm-8pm EST

Please be prepared to supply the following information:

**Factory Order Number or “S-Number”** This is located on an I.D. plate fixed to either the driver’s door panel or the component (axle or transfer case) itself. This plate will also show the component’s model and serial number. Example: S-7777-05

### Component Model and Serial Number

### Vehicle Year, Make and Model

### Vehicle Identification Number

### Mileage

### In Service Date

Please refer to our website ([www.marmon-herrington.com](http://www.marmon-herrington.com)) for the latest versions of our parts and service manuals, as well as new products and contact information.

**The information necessary for replacement parts and/or warranty claim procedures will be found on either plate design.**

<b>MARMON-HERRINGTON</b>	
SALES ORDER	0000-00
RATIO	
S/N	
TYPE	
CUST P/N	

<b>MARMON-HERRINGTON</b>	
SALES ORDER	0000-00
S/N	
TYPE	
CUST P/N	
COVERED BY ONE OR MORE OF THE FOLLOWING PATENTS: U.S. PATENTS 4,878,691; 4,934,733; 5,016,912; 5,275,430; 5,839,750; AND 6,398,251; AND CA PATENT 1,316,185. OTHER U.S. AND FOREIGN PATENTS PENDING.	

<b>MARMON-HERRINGTON</b>	
ALL-WHEEL DRIVE LOUISVILLE, KENTUCKY U.S.A.	
FACTORY ORDER NO.	0000-00
INSTALLED BY	
<b>FRONT DRIVING AXLE</b>	
MODEL	
CAPACITY	
SERIAL NO.	
RATIO	
<b>TRANSFER CASE</b>	
MODEL	
SERIAL NO.	

# DIFFERENTIAL CARRIER HOUSING MT22/R/N/H

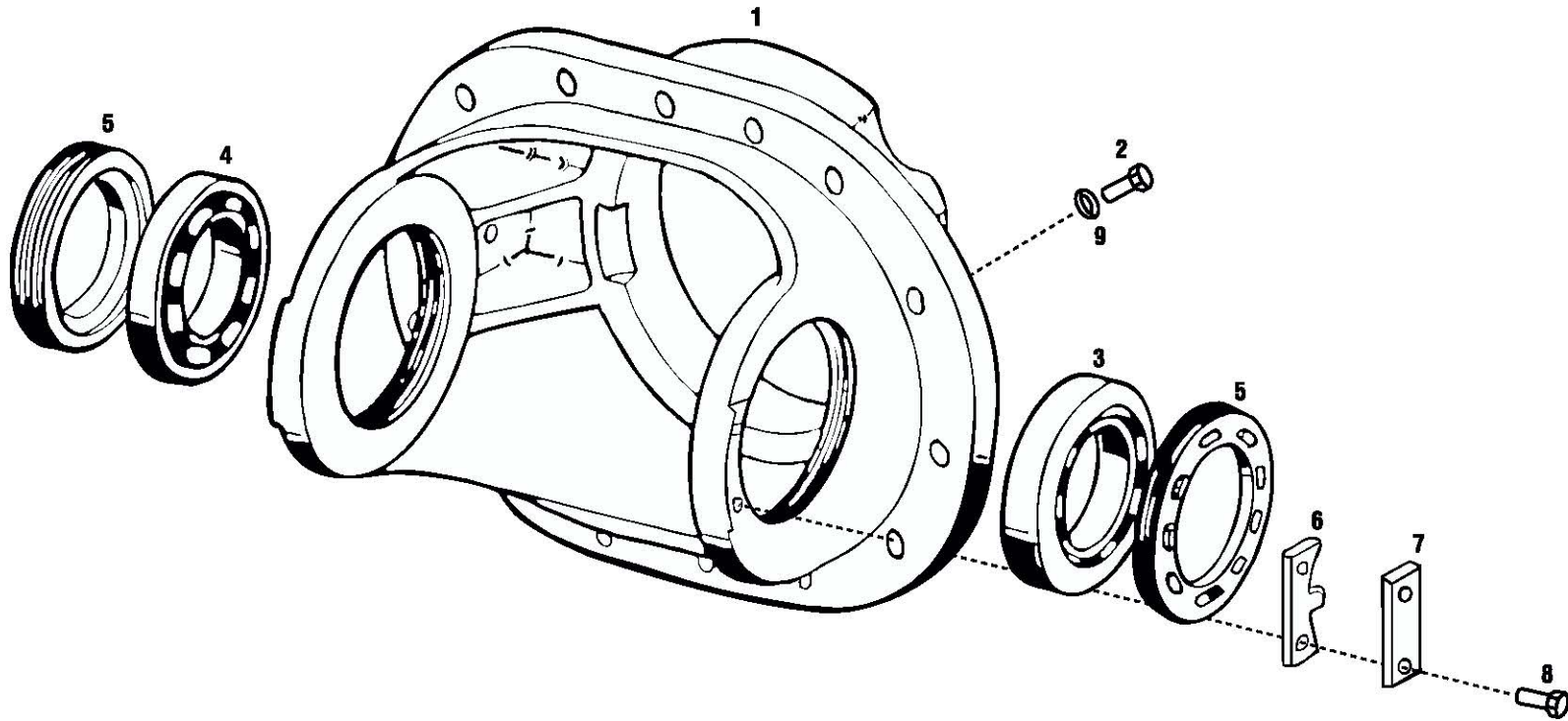

Marmon-Herrington

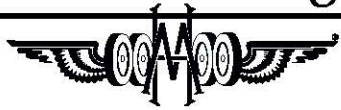



ITEM NO.	MH PART NO.	DESCRIPTION	QTY. REQ.	ITEM NO.	MH PART NO.	DESCRIPTION	QTY. REQ.
1	MT22-1076	Differential Carrier Housing Assy.	1				
2	MT22-1077	Flanged Bolt, Special	14				
	MT22-1277	Flanged Bolt (Use Lock Washer)	14				
3	MT22-1078	Differential Side Bearing Assy.	1				
4	MT22-1212	Differential Side Bearing Assy.	1				
5	MT22-1079	Bearing Adjuster	2				
6	MT22-1080	Lock Plate	2				
7	MT22-1081	Lock Plate	2				
8	11500773	Hex Bolt, M8 X 15 - 10.9	4				
9	MT93-5866	Washer, Lock (Nord-Lock)	14				

**DIFFERENTIAL CARRIER HOUSING**  
**MT22/R/N/H**

# DIFFERENTIAL MT22/R/N/H

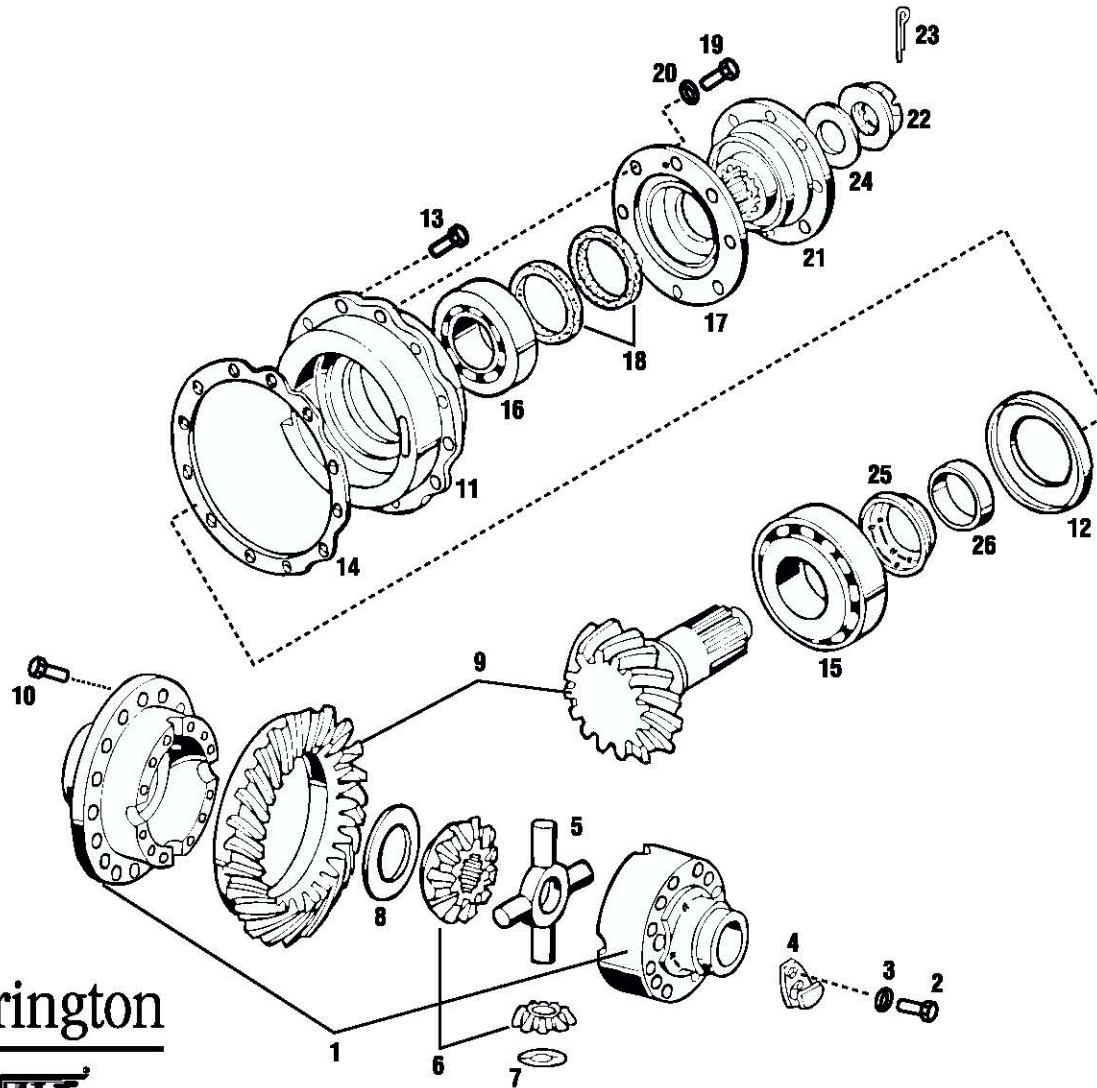

Marmon-Herrington  



COMPLETE CARRIER ASSEMBLY				ITEM NO.	MH PART NO.	DESCRIPTION	QTY. REQ.	
CARRIER P/N	PINION & RING GEAR RATIO	FINAL RATIO	DIFFERENTIAL CASE	10	MT22-1250	Flanged S/L Ring Gear Bolt	16	
MT22-1001	1.227	4.25	MT22-1051	11	MT22-1068	Bearing Cage Assy.	1	
MT22-1002	1.318	4.56	MT22-1051	12	MT14-1078	Oil Baffle Plate	1	
MT22-1003	1.422	4.92	MT22-1052	13	MT22-1077	Flanged Bolt, Special	12	
MT22-1004	1.526	5.29	MT22-1052	14	MT22-1067A	Shim, 1.0 MM	AR	
MT22-1010	1.553	5.38	MT22-1052		MT22-1067B	Shim, .50 MM	AR	
MT22-1005	1.632	5.65	MT22-1052		MT22-1067C	Shim, .30 MM	AR	
MT22-1014	1.684	5.83	MT22-1052		MT22-1067D	Shim, .25 MM	AR	
MT22-1013	1.765	6.11	MT22-1052		MT22-1067E	Shim, .20 MM	AR	
MT22-1006	1.812	6.27	MT22-1052		15	MT14-1075	Pinion Bearing, Inner	1
MT22-1007	1.929	6.68	MT22-1052		16	MT14-1079	Pinion Bearing, Outer	1
MT22-1008	2.077	7.14	MT22-1445	17	MT22-1070	Cover	1	
MT22-1009	2.231	7.72	MT22-1445	18	MT22-1069	Oil Seal Kit, Pinion	1	
MT22-1011	2.415	8.36	MT22-1445		19	11500713	Hex Bolt, M8 X 22	8
MT22-1012	2.462	8.52	MT22-1445	20	11500191	Flat Lock Washer, M8	8	
ITEM NO.	MH PART NO.	DESCRIPTION	QTY. REQ.	21	MT17-1050	Companion Flange, 1610 Series	1	
1	MT22-1051	Diff. Case Halves, Assy. (4.25-4.56)	1		MT22-1073	Companion Flange, 1710 Series	1	
	MT22-1052	Diff. Case Halves, Assy. (4.92-6.68)	1	22	MT22-1075	Pinion Lock Nut	1	
	MT22-1445	Diff. Case Halves, Assy. (7.14-8.52)	1		MT14-1082	Pinion Castle Nut	1	
2	MT22-1066	Hex Bolt, Special	12	23	103422	Cotter Pin	1	
3	MT22-1065	Washer, Special	2	24	MT22-1074	Washer, Special	1	
4	MT22-1064	Oil Baffle Plate	2	25	MT14-1076	Distance Sleeve	1	
5	MT22-1061	Differential Cross	1	26*	MT14-1077A	Bearing Distance Ring, 6.90 MM	AR	
6	MT22-1193	Nest Set	1		MT14-1077B	Bearing Distance Ring, 7.00 MM	AR	
7	MT22-1063	Washer, Differential Pinion Gear	4		MT14-1077C	Bearing Distance Ring, 7.02 MM	AR	
8	MT22-1059	Washer, Differential Side Gear	2		MT14-1077D	Bearing Distance Ring, 7.04 MM	AR	
9	MT22-1054	Ring Gear and Pinion (1.227) 4.25	1		MT14-1077E	Bearing Distance Ring, 7.06 MM	AR	
	MT22-1053	Ring Gear and Pinion (1.318) 4.56	1		MT14-1077F	Bearing Distance Ring, 7.08 MM	AR	
	MT22-1056	Ring Gear and Pinion (1.422) 4.92	1		MT14-1077G	Bearing Distance Ring, 7.10 MM	AR	
	MT22-1057	Ring Gear and Pinion (1.526) 5.29	1		MT14-1077H	Bearing Distance Ring, 7.20 MM	AR	
	MT22-1043	Ring Gear and Pinion (1.553) 5.38	1		MT14-1077I	Bearing Distance Ring, 7.32 MM	AR	
	MT22-1055	Ring Gear and Pinion (1.632) 5.65	1		MT14-1077J	Bearing Distance Ring, 7.44 MM	AR	
	MT22-1047	Ring Gear and Pinion (1.684) 5.83	1		MT14-1077K	Bearing Distance Ring, 7.56 MM	AR	
	MT22-1046	Ring Gear and Pinion (1.765) 6.11	1		MT14-1077L	Bearing Distance Ring, 7.68 MM	AR	
	MT22-1058	Ring Gear and Pinion (1.812) 6.27	1		MT14-1077M	Bearing Distance Ring, 7.80 MM	AR	
	MT22-1040	Ring Gear and Pinion (1.929) 6.68	1		MT14-1077N	Bearing Distance Ring, 7.92 MM	AR	
MT22-1041	Ring Gear and Pinion (2.077) 7.14	1						
MT22-1042	Ring Gear and Pinion (2.231) 7.72	1						
MT22-1044	Ring Gear and Pinion (2.415) 8.36	1						
MT22-1045	Ring Gear and Pinion (2.462) 8.52	1						

AR = As Required  
**\*Note:** Choose 2 to produce proper bearing preload.

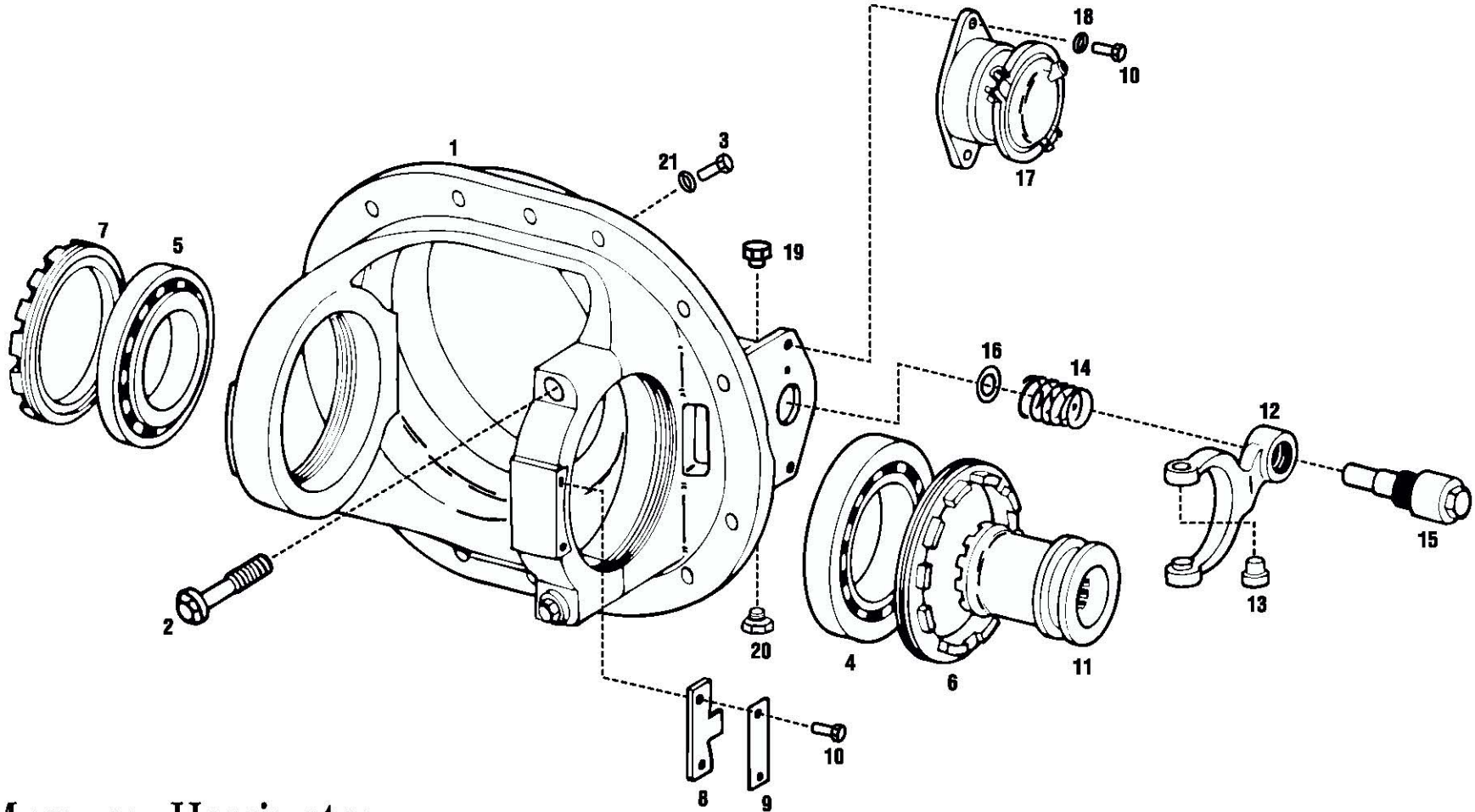
# DIFFERENTIAL CARRIER HOUSING MTL22

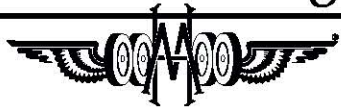

Marmon-Herrington



ITEM NO.	MH PART NO.	DESCRIPTION	QTY. REQ.	ITEM NO.	MH PART NO.	DESCRIPTION	QTY. REQ.
1	R22-1030	Differential Carrier Housing Assy.	1				
2	R22-1028	Hex Bolt, M16x85-1.5	2				
3	MT22-1077	Flanged Bolt, Special	14				
	MT22-1277	Flanged Bolt (Use Lock Washer)	14				
4	MT14-1053	Taper Roller Bearing	1				
5	MT22-1078	Taper Roller Bearing	1				
6	MT14-1052	Bearing Adjuster, M142x1.5	1				
7	MT22-1079	Bearing Adjuster, M133x2	1				
8	MT22-1080	Adjuster Lock Plate	2				
9	MT22-1081	Lock Plate	2				
10	11500773	Hex Bolt, M8x16	6				
11	MTL17-1027	Clutch Sleeve	1				
12	R22-1058	Shift Fork Assy. <b>(Includes Item #13)</b>	1				
13	R22-1059	Shift Fork Pin	2				
14	R22-1015	Spring	1				
15	R22-1016	Push Rod	1				
16	R22-1017	Washer	AR				
17	R22-1021	Differential Lock Actuating Air Chamber Assy.	1				
18	11500191	Lock Washer, M8	2				
19	3152X2	Plug	1				
20	R22-1060	Plug with Sealant	2				
21	MT93-5866	Washer, Lock (Nord-Lock)	14				
		AR = As Required					

# DIFFERENTIAL MTL22

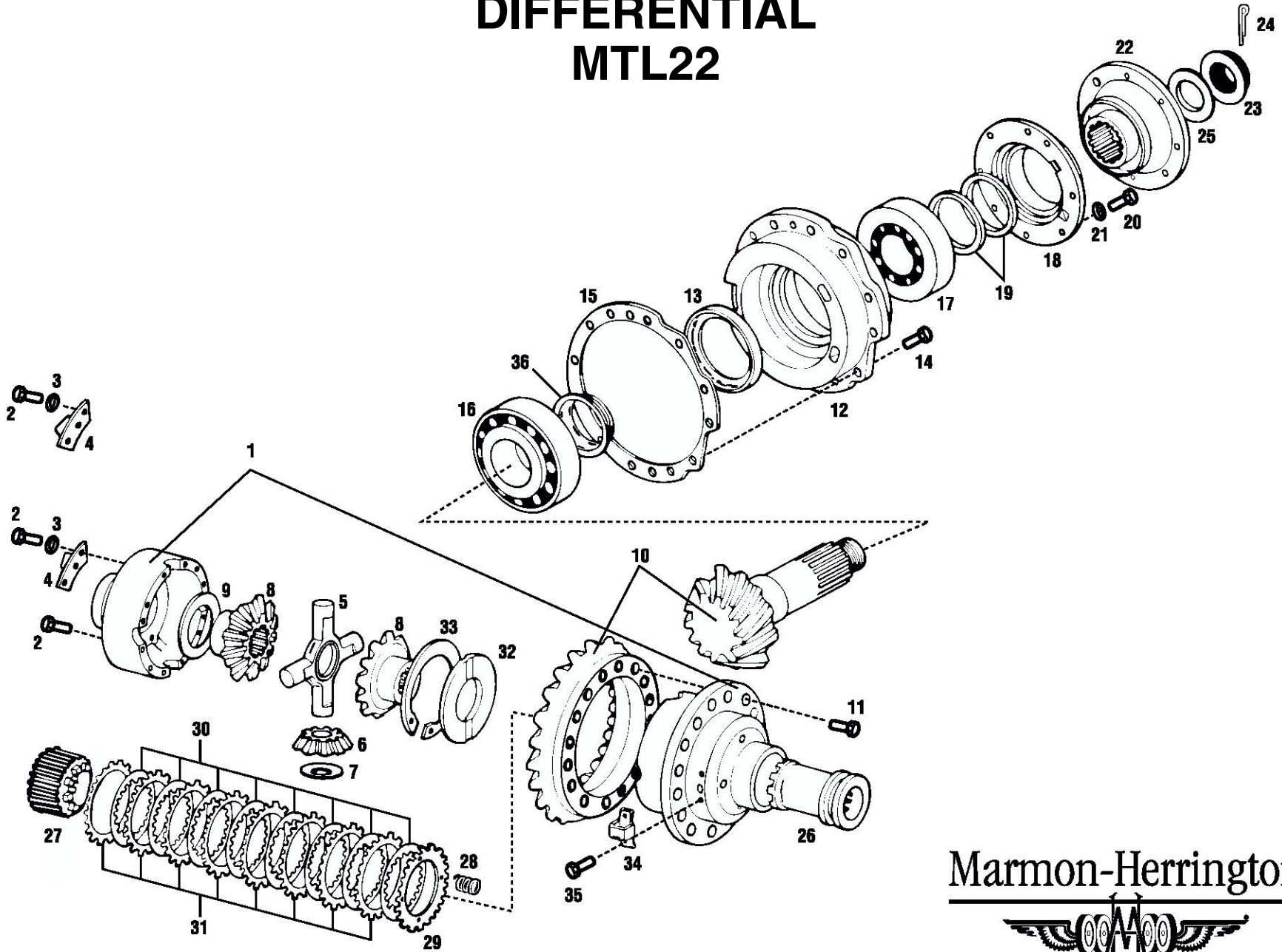

Marmon-Herrington

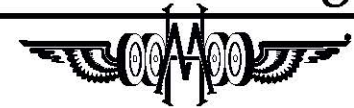

COMPLETE CARRIER ASSEMBLY				ITEM NO.	MH PART NO.	DESCRIPTION	QTY. REQ.	
CARRIER P/N	PINION & RING GEAR RATIO	FINAL RATIO	DIFFERENTIAL CASE	16	MT14-1075	Pinion Bearing, Inner	1	
MTL17-1001	1.227	4.25	MTL17-1022	17	MT14-1079	Pinion Bearing, Outer	1	
MTL17-1002	1.318	4.56	MTL17-1022	18	MT22-1070	Cover	1	
MTL17-1003	1.422	4.92	MTL17-1023	19	MT22-1069	Oil Seal Kit, Pinion	1	
MTL17-1004	1.526	5.29	MTL17-1023	20	11500713	Hex Bolt, M8x20-1.25	8	
MTL17-1010	1.553	5.38	MTL17-1023	21	11500191	Lock Washer, M8	8	
MTL17-1005	1.632	5.65	MTL17-1023	22	MT22-1073	Companion Flange, 1710 Series	1	
MTL17-1014	1.684	5.83	MTL17-1023	23	MT14-1082	Pinion Castle Nut, M42x1.5	1	
MTL17-1013	1.765	6.11	MTL17-1023	24	103422	Cotter Pin	1	
MTL17-1006	1.812	6.27	MTL17-1023	25	MT22-1074	Washer, Special	1	
MTL17-1015	1.929	6.68	MTL17-1023	26	MTL17-1027	Clutch Sleeve	1	
ITEM NO.	MH PART NO.	DESCRIPTION	QTY. REQ.	27	MTL17-1028	Toothed Hub	1	
1	MTL17-1023	Diff. Case Halves, Assy. (4.92-6.68)	1	28	MTL17-1029	Spring	12	
	MTL17-1022	Diff. Case Halves, Assy. (4.25-4.56)	1	29	MTL17-1030	Backing Disk	1	
2	MT22-1066	Hex Bolt, M10x75-1.25	12	30	MTL22-1053	Inner Clutch Plate	13	
3	MT22-1065	Washer	2	31	MTL22-1052	Outer Clutch Plate	13	
4	MTL17-1025	Oil Slinger	2	32	MTL17-1032	Differential Side Washer	1	
5	MT22-1061	Differential Cross	1	33	MTL17-1033	Lock Ring	1	
6	MT22-1062	Differential Pinion	4	34	MTL17-1034	Oiler Scoop	2	
7	MT22-1063	Washer, Differential Pinion Gear	4	35	MTL17-1035	Countersunk Screw	2	
8	MTL17-1026	Differential Gear	2	36	<b>Pinion Bearing Spacer:*</b>			
9	MT22-1059	Washer, Differential Side Gear	1		MT22-1400	34.225 MM	MT22-1417	33.800 MM
10	MT22-1054	Ring Gear and Pinion (1.227) 4.25	1		MT22-1401	34.200 MM	MT22-1418	33.775 MM
	MT22-1053	Ring Gear and Pinion (1.318) 4.56	1		MT22-1402	34.175 MM	MT22-1419	33.750 MM
	MT22-1056	Ring Gear and Pinion (1.422) 4.92	1		MT22-1403	34.150 MM	MT22-1420	33.725 MM
	MT22-1057	Ring Gear and Pinion (1.526) 5.29	1		MT22-1404	34.125 MM	MT22-1421	33.700 MM
	MT22-1043	Ring Gear and Pinion (1.553) 5.38	1		MT22-1405	34.100 MM	MT22-1422	33.675 MM
	MT22-1055	Ring Gear and Pinion (1.632) 5.65	1		MT22-1406	34.075 MM	MT22-1423	33.650 MM
	MT22-1047	Ring Gear and Pinion (1.684) 5.83	1		MT22-1407	34.050 MM	MT22-1424	33.625 MM
	MT22-1046	Ring Gear and Pinion (1.765) 6.11	1		MT22-1408	34.025 MM	MT22-1425	33.600 MM
	MT22-1058	Ring Gear and Pinion (1.812) 6.27	1		MT22-1409	34.000 MM	MT22-1426	33.575 MM
	MT22-1040	Ring Gear and Pinion (1.929) 6.68	1		MT22-1410	33.975 MM	MT22-1427	33.550 MM
11	MT22-1250	Flanged, Self-Locking Ring Gear Bolt	16		MT22-1411	33.950 MM	MT22-1428	33.525 MM
12	MT22-1068	Bearing Cage Assy.	1		MT22-1412	33.925 MM	MT22-1429	33.500 MM
13	MT14-1078	Oil Baffle Plate	1		MT22-1413	33.900 MM	MT22-1430	33.475 MM
14	MT22-1077	Flanged Bolt, Special	12		MT22-1414	33.875 MM	MT22-1431	33.450 MM
15	MT22-1067A	Shim, 1.0 MM	AR		MT22-1415	33.850 MM	MT22-1432	33.425 MM
	MT22-1067B	Shim, .50 MM	AR		MT22-1416	33.825 MM	MT22-1433	33.400 MM
	MT22-1067C	Shim, .30 MM	AR					
	MT22-1067D	Shim, .25 MM	AR					
	MT22-1067E	Shim, .20 MM	AR					

AR = As Required

**\*Note:**  
As Required.  
Choose 1 to produce  
proper bearing preload.

# DIFFERENTIAL LOCK AIR CHAMBER MTL22

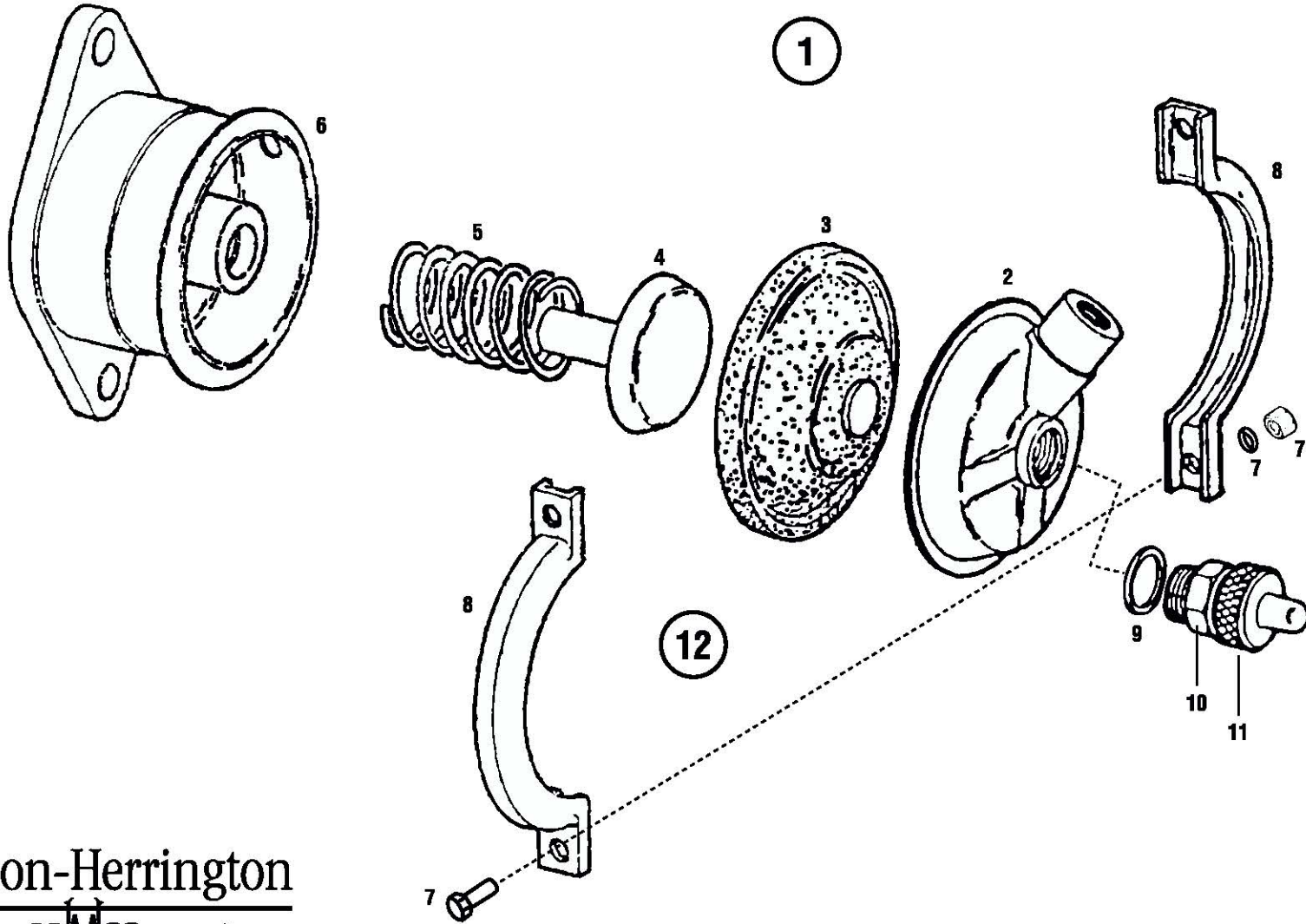

Marmon-Herrington  



ITEM NO.	MH PART NO.	DESCRIPTION	QTY. REQ.	ITEM NO.	MH PART NO.	DESCRIPTION	QTY. REQ.
1	R22-1021	Differential Lock Actuating Air Chamber Assy. <b>(Includes Items #2, 3, 4, 5, 6, 7, and 8)</b>	2				
2	R22-1022	Cap*	1				
3	R22-1023	Diaphragm*	1				
4	R22-1024	Spring Cap*	1				
5	R22-1025	Spring*	1				
6	R22-1026	Housing*	1				
7	R22-1032	Clamp, Bolt Kit*	1				
8	R22-1029	Clamp*	2				
9	MVG12-1040	Washer (Non-Military Only)	1				
10	MVG12-1041	Reporting Switch (Non-Military Only)	1				
11	MT75-7750	Connecting (Non-Military Only)	1				
12	R22-1023K	Diaphragm Kit <b>(Includes Items #3, 7, 8)</b>	1				
		*Not Sold Separately					

# AXLE HOUSING MT22/R/N/H

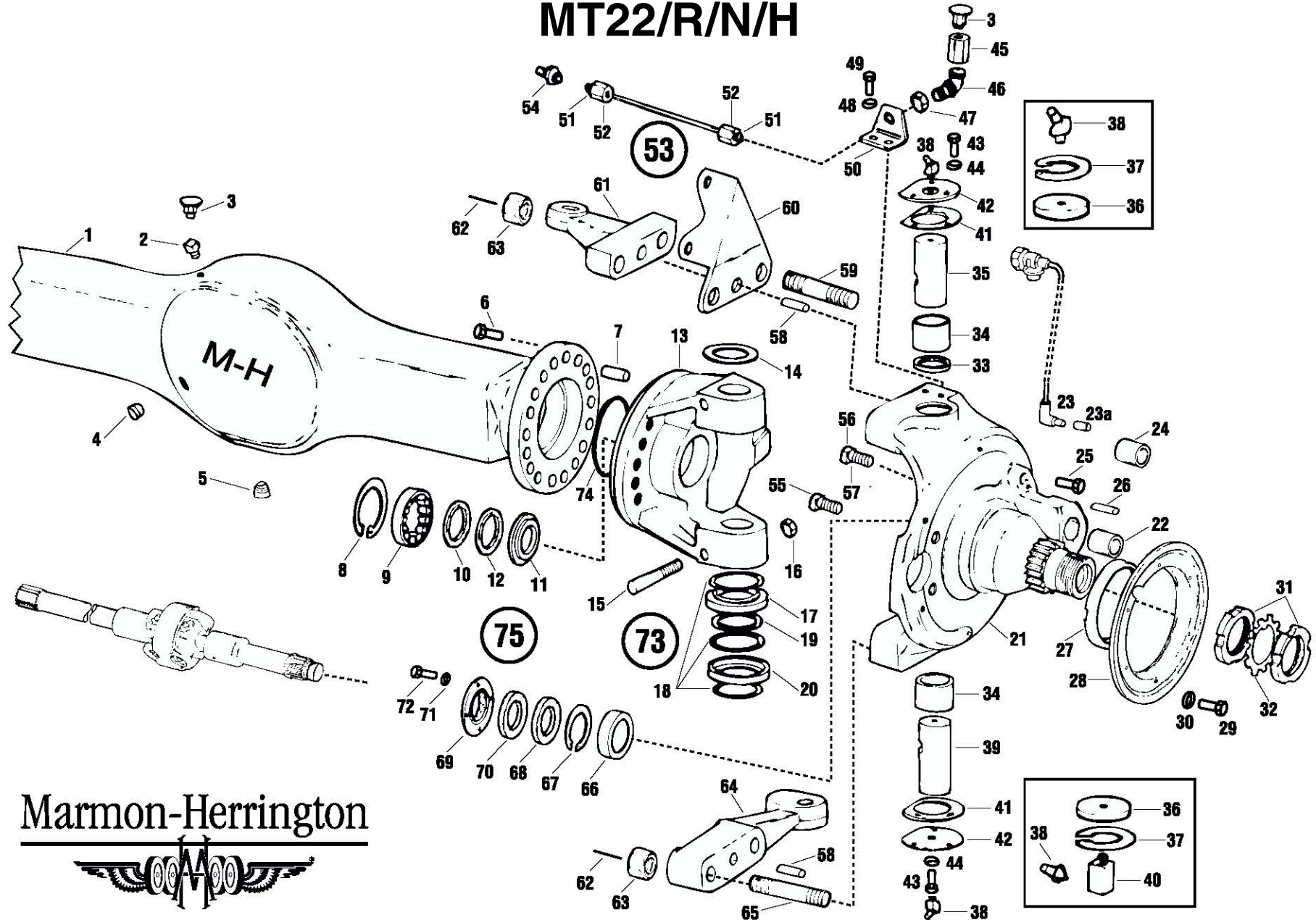

Marmon-Herrington  



ITEM NO.	MH PART NO.	DESCRIPTION	QTY. REQ.	ITEM NO.	MH PART NO.	DESCRIPTION	QTY. REQ.
1	MT22-1083	Axle Housing	1	37	MT22-1109	Snap Ring	4
	MT22R-1038	Axle Housing (MT22R/N Only)	1	38	271285	Grease Fitting 45°	4
2	MT22-1214	Vent Extension	1	39	MT22-1111	Trunnion Pin, Lower (Long)	2
3	MT14-1068	Vent	3	40	MT22-1113	Adapter	2
4	MT14-1070	Fill Plug	1	41	MT22-1108G	Trunnion Cover Gasket	4
5	MT14-1071	Drain Plug, Magnetic	1	42	MT22-1108A	Trunnion Cover	4
6	MT22-1084	Hex Bolt, Special	36	43	11500713	Bolt M8 X 20 - 1.25	12
7	MT14-1222	Dowel Pin	2	44	11500191	Lock Washer M8	12
8	MT22-1087	Snap Ring	2	45	MT22-1139	Adapter Fitting	2
9	MT22-1088	Roller Bearing, Axle Shaft, Inner	2	46	MT22-1138	Elbow Fitting, Vent	2
10	MT22-1089	Oil Seal, Axle Shaft, Inner	2	47	MT22-1140	Jam Nut	2
11	MT22-1090	Seal Holder	2	48	11500192	Lock Washer, M10	4
12	MT22-1090F	Felt Wiper	2	49	11500778	Hex Bolt, M10 X 25	4
13	MT22-1085	Yoke Housing, L.H.	1	50	MT22-1135	Bracket, Vent, L.H.	1
	MT22-1086	Yoke Housing, R.H. (Not Shown)	1		MT22-1136	Bracket, Vent, R.H. (Not Shown)	1
14	MT22-1091A	Shim, Trunnion, 1.00 MM	AR	51	MT22-1141	Retaining Ring	4
	MT22-1091B	Shim, Trunnion, 1.20 MM	AR	52	MT22-1142	Union Nut	4
	MT22-1091C	Shim, Trunnion, 0.40 MM	AR	53	MT22-1143A	Tube Vent, L.H. (Includes Items #51 and 52)	1
	MT22-1091D	Shim, Trunnion, 0.60 MM	AR		MT22-1143B	Tube Vent, R.H.	1
	MT22-1091E	Shim, Trunnion, 1.40 MM	AR	54	MT22-1144	Pipe Fitting	2
15	MT22-1092	Lock Pin	4	55	MT22-1110	Bolt M20 X 60 - 1.5	2
16	MT22-1093	Hex Nut, Fine Thread, M16 X 1.5	4	56	MT22-1125	Bolt, Turn Stop M20 X 47 - 1.5	2
17	MT22-1097	Bearing Case, Upper	2		MT93-5854	Bolt, Turn Stop M20 X 80 - 1.5	2
18	MT22-1095	O Ring	2	57	MT22-1126	Hex Nut, Special	2
19	MT22-1096	Thrust Disk	2	58	MT22-1103	Dowel Pin	4
20	MT22-1094	Bearing Case, Lower	2	59	MT22-1127	Stud, Steering Arm	4
21	MT22-1098	Knuckle - Spindle Assy., L.H.	1	60	MT22-1128	Brake Chamber Bracket, L.H.	1
	MT22-1099	Knuckle - Spindle Assy., R.H. (Not Shown)	1		MT22-1129	Brake Chamber Bracket, R.H.	1
21a	MT22R-1098	Knuckle Assy., L.H. (MT22R Only)	1	61	MT22-1130	Steering Arm, L.H.	1
	MT22R-1099	Knuckle Assy., R.H. (MT22R Only)	1		MT22-1131	Steering Arm, R.H. (Not Shown)	1
21b	MT22N-1098	Knuckle Assy., L.H. (MT22N Only)	1	62	85T23	Lock Wire	AR
	MT22N-1099	Knuckle Assy., R.H. (MT22N Only)	1	63	MT22-1124	Castle Nut	8
22	MT22-1100	Pin, Brake Shoe (MT22/R Only)	2	64	MT22-1120	Tie Rod Arm, L.H.	1
23	MT93-1282	ABS Sensor (Wabco)	2		MT22-1320	Tie Rod Arm, L.H. (0000, 11, 06)	1
	MT93-2035	ABS Sensor (Bendix)	2		MT22-1121	Tie Rod Arm, R.H. (Not Shown)	1
23a	MT93-1283	Sensor Spring Clip	2		MT22-1321	Tie Rod Arm, R.H. (Not Shown) (0000, 11, 06)	1
24	MT22-1241	Bushing, Brake Shoe Pin (MT22N Only)	4	65	MT22-1122	Stud, Tie Rod Arm	4
25	MT22-1105	Hex Bolt, Special	4		MT22-1127	Stud, Steering Arm/Tie Rod Arm (0000, 11, 06)	4
26	MT22-1106	Dowel Pin	4	66	MT22-1114	Roller Bearing, Axle Shaft, Outer	2
27	MT22-1104	Wear Sleeve Hub Seal (MT22 Only)	2	67	MT22-1115	Snap Ring	2
28	MT22-1176	Dust Shield	2	68	MT22-1116	Oil Seal, Axle Shaft, Outer	2
29	11500773	Hex Bolt, M8 X 16	12	69	MT22-1117	Dust Shield, Axle Shaft	2
30	11500191	Lock Washer, M8	12	70	MT10-1080	Felt	2
31	MT22-1132	Nut, Wheel Bearing	4	71	11500190	Lock Washer, M6	8
32	MT22-1133	Lock Ring, Wheel Bearing	2	72	11503946	Hex Bolt, M6 X 12	8
33	MT22-1101	Oil Seal, Trunnion Pin	4	73	MT22-1215	Thrust Bearing Kit (Incl. Items #17, 18, 19, 20)	2
34	MT22-1102	Trunnion Pin Bushing	4	74	MT22-1285	O-Ring (119 X 5)	2
35	MT22-1107	Trunnion Pin, Upper (Short)	2	75	MT22-1205	Seal Holder Assembly (Incl. Items #10, 11, 12)	2
36	MT22-1108	Cover, Trunnion Pin	4			AR = As Required	

**AXLE HOUSING — MT22/R/N/H**

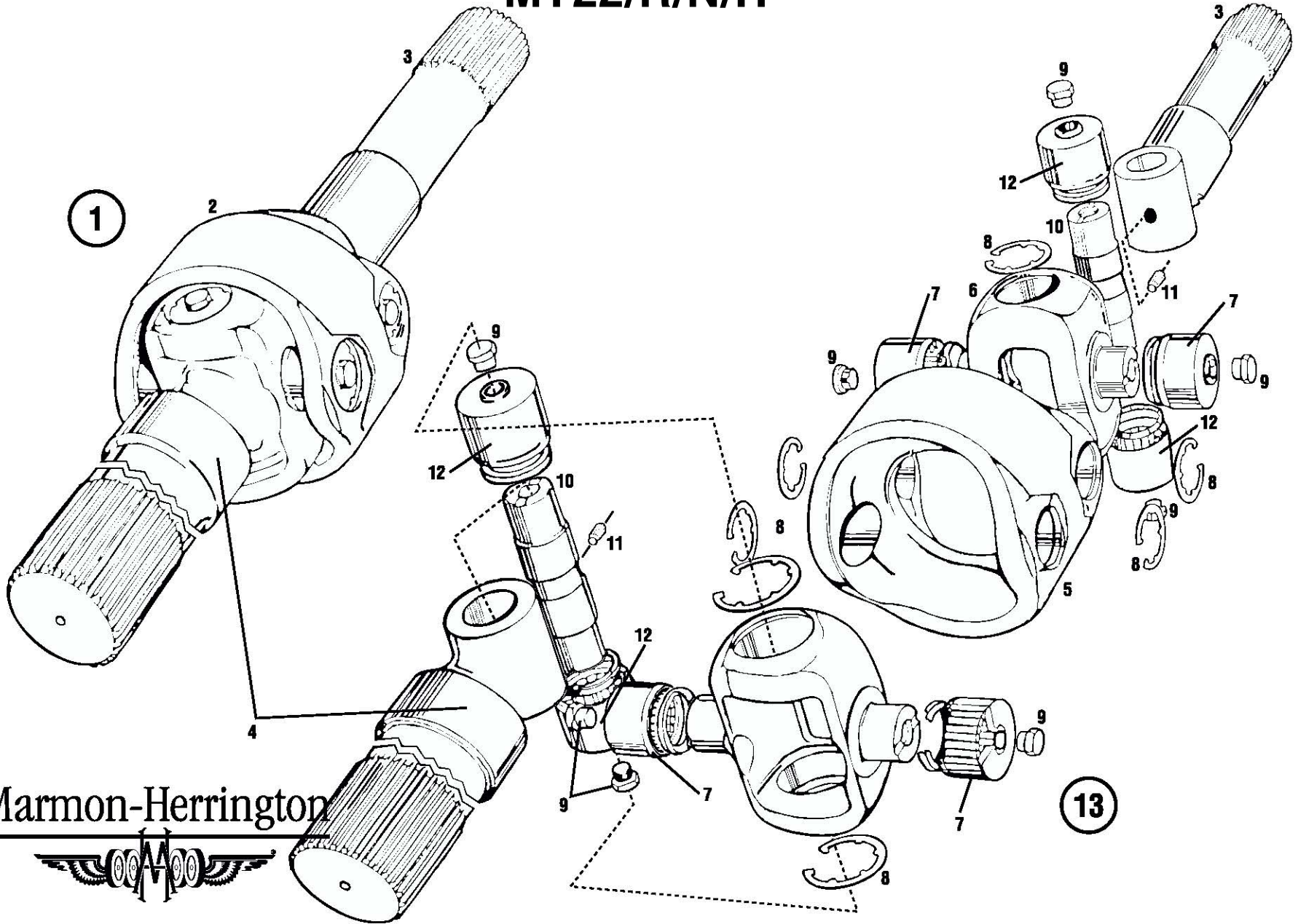
# AXLE SHAFT ASSEMBLY MT22/R/N/H

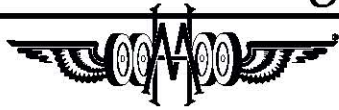

Marmon-Herrington



ITEM NO.	MH PART NO.	DESCRIPTION	QTY. REQ.	ITEM NO.	MH PART NO.	DESCRIPTION	QTY. REQ.
1	MT22-1146	Axle Shaft Assy., Complete (MT22 Only)	2				
	MT22R-1177	Axle Assy., Short Spline (MT22R/N/H Only)*	1				
	MT22R-1178	Axle Assy., Long Spline (MT22R/N/H Only)*	1				
	MT22-1206	Axle Shaft Assy., Short Spline**	1				
	MT22-1207	Axle Shaft Assy., Long Spline**	1				
2	MT22-1147	Double Cardan Steering Joint*	2				
3	MT22-1148	Outer Axle Shaft*	2				
4	MT22-1149	Inner Axle Shaft (MT22 Only)*	2				
	MT22R-1145	Axle Shaft Inner, Short Spline (MT22R/N/H Only)*	1				
	MT22R-1149	Axle Shaft Inner, Long Spline (MT22R/N/H Only)*	1				
5	MT22-1225	Couple Housing, Cardan Joint*	2				
6	MT22-1226	Cross Shaft*	NSS				
7	MT22-1227	Bearing Cup Assy., Cross Shaft*	NSS				
8	MT22-1228	Snap Ring*	16				
9	MT22-1229	Plug, Bearing Cup, M12 X 1.5*	16				
10	MT22-1230	Pin, Axle Shaft*	NSS				
11	MT22-1231	Set Screw, Axle Pin*	4				
12	MT22-1232	Bearing Cup Assy., Axle Pin*	NSS				
13	MT10-1134	Cardan Steering Joint Kit* <b>(Includes Items #7, 8, 9, 10, 11, 12)</b>	4				
		NSS = Not Sold Separately *Fits axles with serial #9999-05-02 or less. **Fits all MT22R/N/H axles.					

# PLANETARY MT22/R/N/H

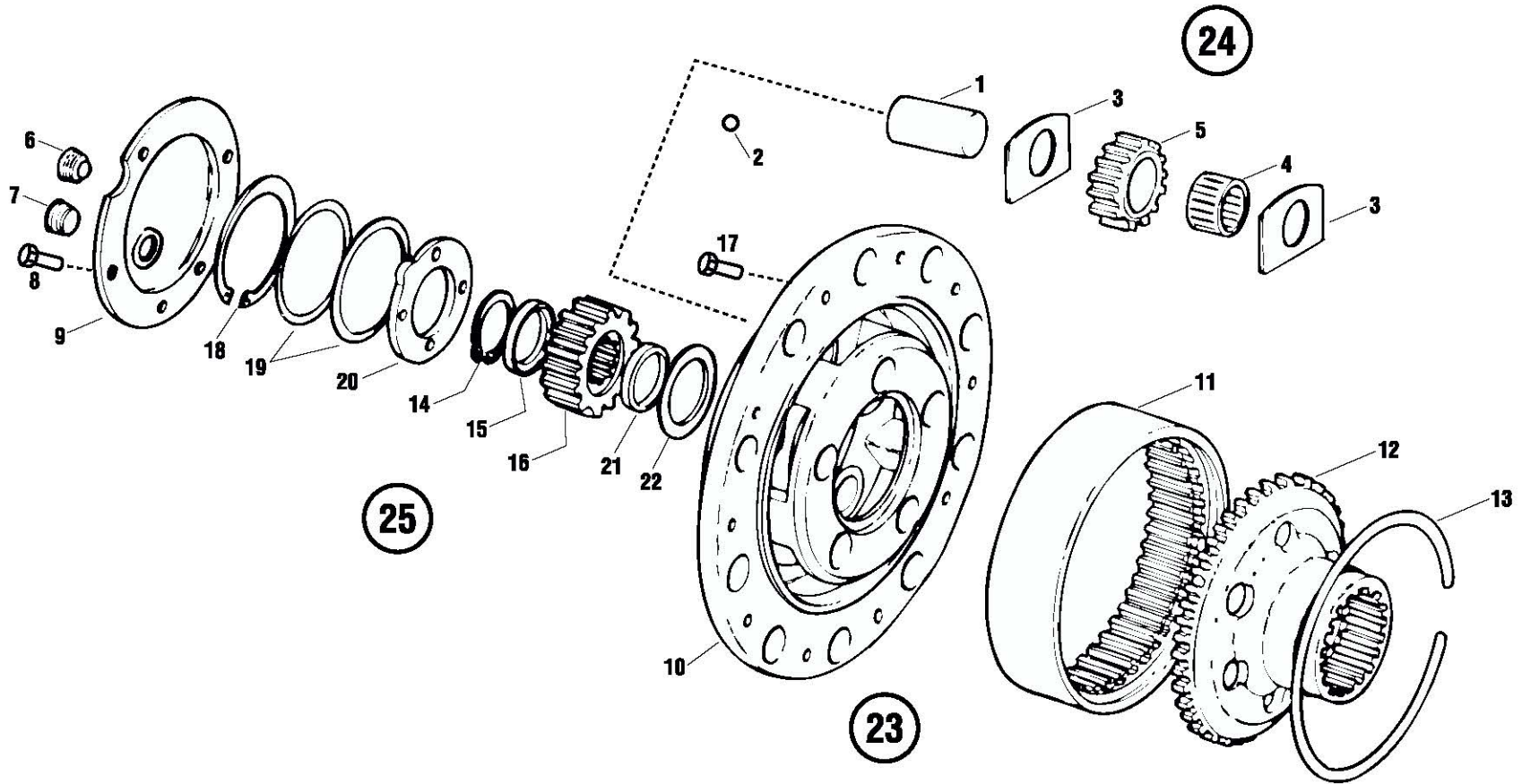

Marmon-Herrington

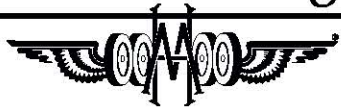

ITEM NO.	MH PART NO.	DESCRIPTION	QTY. REQ.	ITEM NO.	MH PART NO.	DESCRIPTION	QTY. REQ.
1	MT14-1217	Planet Gear Pin	10				
2	MT14-1218	Steel Ball	10				
3	MT14-1219	Distance Plate	20				
4	MT14-1220	Roller Bearing Assy.	10				
5	MT14-1028	Planet Gear	10				
6	MT14-1071	Magnetic Drain Plug	2				
7	MT14-1070	Fill Plug	2				
8	11500723	Hex Bolt, M10 X 20	10				
9	MT22-1156	End Cover	2				
10	MT22-1161	Planet Gear Carrier	2				
	MT22H-1161	Planet Gear Carrier Hub Pilot (MT22H Only)	2				
11	MT22-1162	Planetary Ring Gear	2				
12	MT22-1163	Ring Gear Support Hub	2				
13	MT14-1207	Retaining Ring	2				
14	MT22-1154	Snap Ring	2				
15	MT22-1153	Spacer	2				
16	MT22-1152	Sun Gear	2				
17	11500724	Hex Bolt, M10 X 30	12				
18	MT14-1084	Snap Ring	2				
19	MT22-1158A	Shim, 0.25 MM	AR				
	MT22-1158B	Shim, 0.50 MM	AR				
	MT22-1158C	Shim, 2.00 MM	AR				
20	MT22-1159	Friction Disk	2				
21	MT22-1151	Distance Ring	2				
22	MT22-1150	Friction Disk	2				
23	MT22-1200	Planet Gear Carrier Assy. (MT22/R/N Only) <b>(Includes Items #1, 2, 3, 4, 5 and 10)</b>	2				
	MT22H-1200	Planet Gear Carrier Assy. (MT22H Only) <b>(Includes Items #1, 2, 3, 4, 5 and 10)</b>	2				
24	MT14-1223	Planet Gear Kit <b>(Includes Items #1, 2, 3, 4 and 5)</b>	2				
25	MT22-1252	Sun Gear/Friction Disk Kit <b>(Includes Items #14, 15, 16, 18, 19, 20, 21, 22)</b> AR = As Required	2				

# WHEEL HUB, BRAKE DRUM MT22/R/N/H

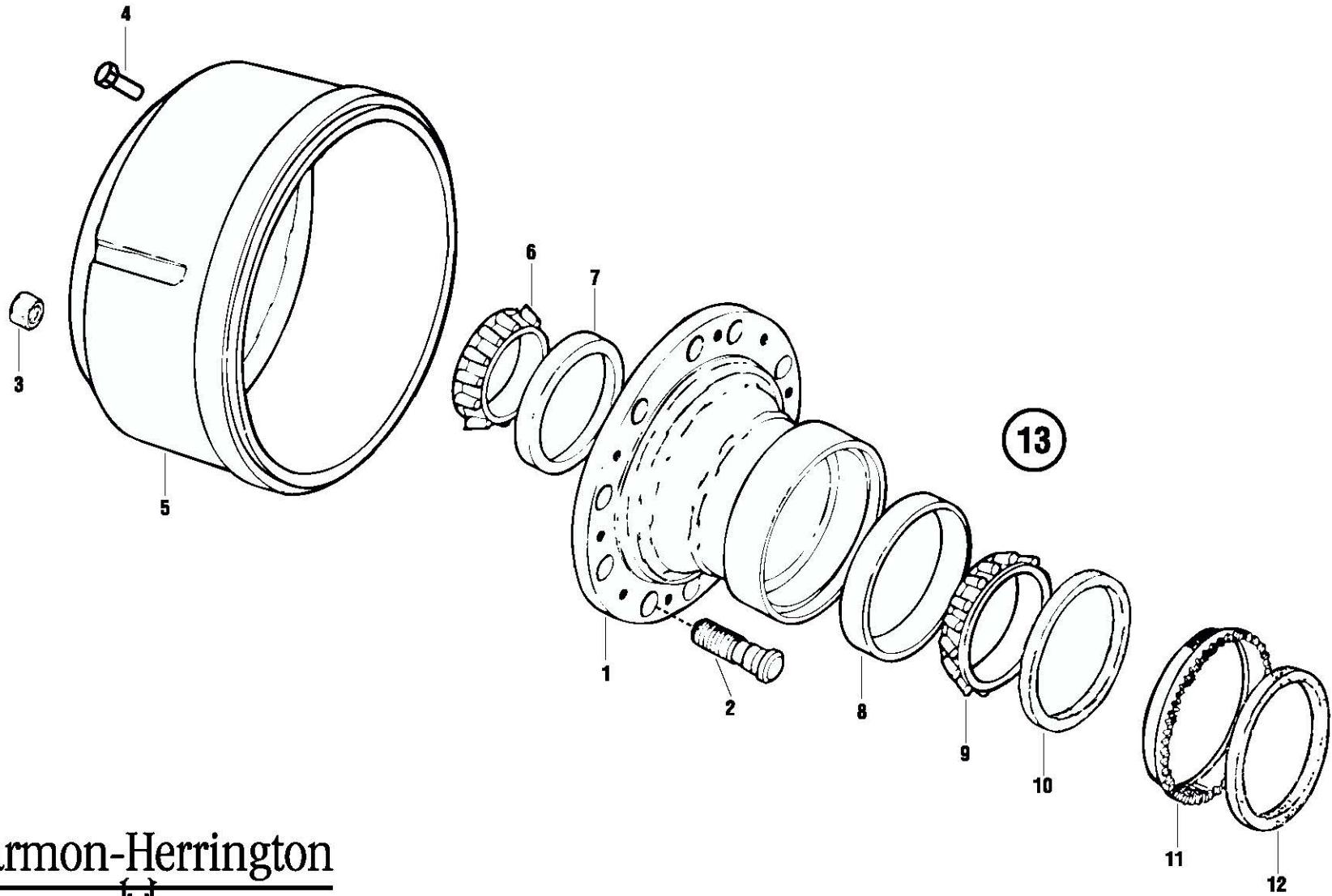

Marmon-Herrington  



ITEM NO.	MH PART NO.	DESCRIPTION	QTY. REQ.	ITEM NO.	MH PART NO.	DESCRIPTION	QTY. REQ.
1	MT22-1168	Hub Assy. (MT22 Only) <b>(Includes Items #2, 7, 8, 9, 10)</b>	2				
	MT22R-1168	Hub Assy. (MT22R/N Only) <b>(Includes Items #2, 6, 7, 8, 9, 11, 12)</b>	2				
	MT22H-1168	Hub Assy. (MT22H Only) <b>(Includes Items #2, 6, 7, 8, 9, 11, 12)</b>	2				
	MT22N-1168	Hub Assy., L.H. (MT22N Only) <b>(Includes Items #2, 6, 7, 8, 9, 11, 12)</b>	1				
2	MT93-2931	Wheel Stud, L.H., Long (MT22N Only)	10				
	MT93-2932	Wheel Stud, R.H., Long (4.625)	20				
	MT22-1134	Wheel Stud Hub Pilot (MT22H Only)	20				
3	67011	Wheel Nut, R.H.	20				
	67012	Wheel Nut, L.H. (MT22N Only)	10				
	MT93-1197	Flange Wheel Nut (MT22H Only)	20				
4	11500779	Hex Bolt, M10 X 40	4				
5	MT22-1165	Brake Drum	2				
	MT22-1165W	Brake Drum	2				
6	MT22-1166	Wheel Bearing, Cone, Outer	2				
7	MT22-1167	Wheel Bearing, Cup, Outer	2				
8	MT22-1170	Wheel Bearing, Cup, Inner	2				
9	MT22-1171	Wheel Bearing, Cone, Inner	2				
10	MT22-1172	Oil Seal, Hub (MT22 Only)	2				
11	MT22R-1164	Exciter Ring (MT22R/N/H Only)	2				
12	MT22R-1172	Hub Seal (MT22R/N/H Only)	2				
13	MT22-1216	Bearing Kit Hub <b>(Includes Items #6, 7, 8, 9)</b>	1				
		AR = As Required					

# BRAKE MT22/R/N/H

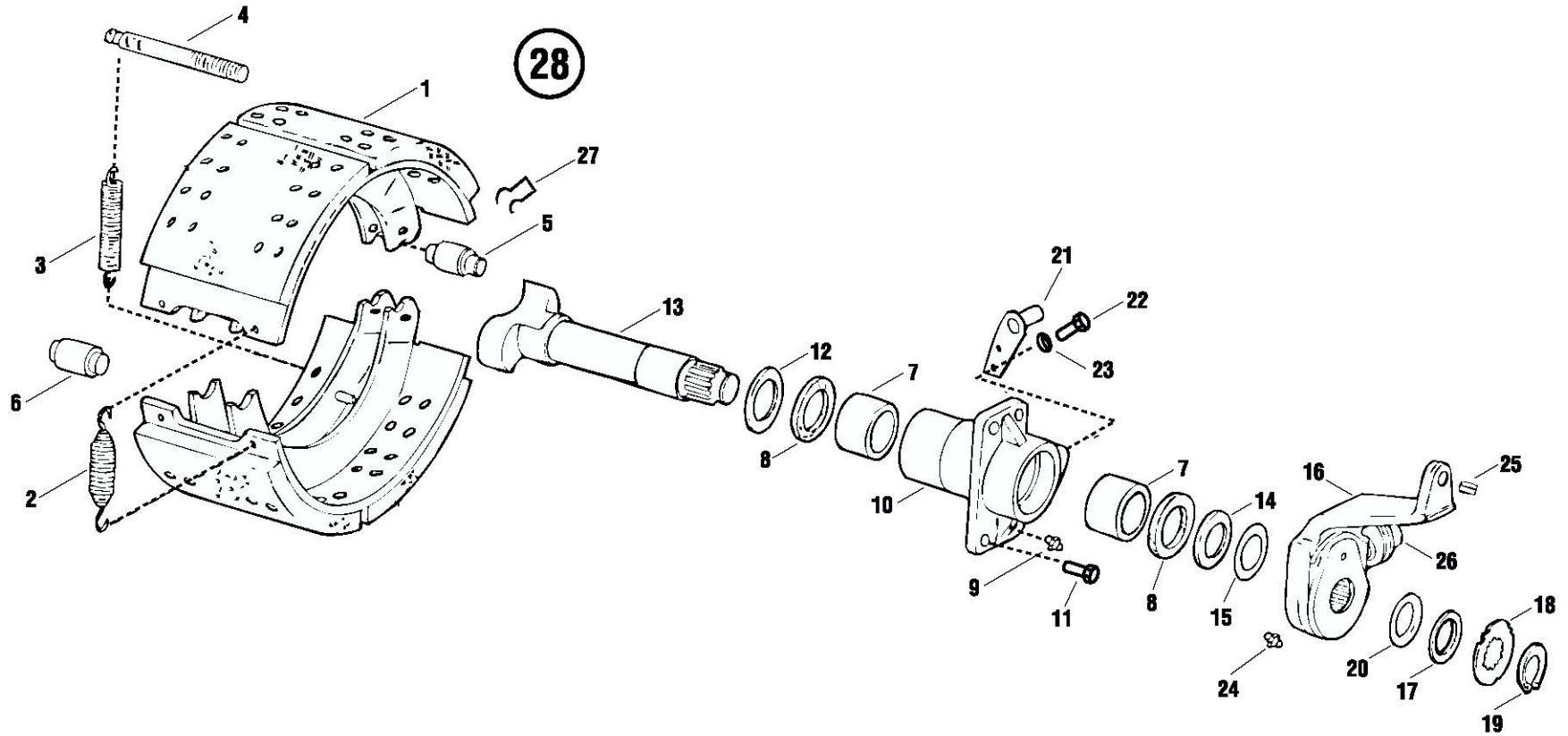

Marmon-Herrington  

ITEM NO.	MH PART NO.	DESCRIPTION	QTY. REQ.	ITEM NO.	MH PART NO.	DESCRIPTION	QTY. REQ.
1	MT14-1155	Brake Shoe Assy. (MT22/R Only)	4	17	MT22-1185	Spacer	2
	MT22-1164	Brake Shoe Assy. (MT22N/H Only)	4	18	MT22-1187	Wear Indication Disk	2
	MT22-1255	Brake Shoe Kit (MT22N/H Only) <b>(Includes Item #28)</b>	2	19	MT22-1186	Snap Ring	2
2	MT14-1156	Return Spring, Long (MT22/R Only)	4	20	MT14-1128	Snap Ring	4
	MT22-1177	Brake Shoe Return Spring (MT22N/H Only)	4	21	MT22-1239	Bumper Assy., L.H. (MT22N/H Only)	1
3	MT14-1157	Return Spring, Short	4		MT22-1240	Bumper Assy., R.H. (MT22N/H Only)	1
4	MT22-1173	Pin, Spring Support	4	22	11500866	Bolt M8 X 14 - 1.25 (MT22N/H Only)	4
5	MT22-1178	Brake Shoe Roller (MT22N/H Only)	4	23	11500191	Lock Washer M8	4
6	MT22-1243	Brake Shoe Pin (MT22N/H Only)	4	24	191758	Grease Fitting, 1/8	2
					191759	Grease Fitting, M8 X 1.00	2
7	MT22-1180	Bushing	4	25	MT14-1131	Bushing	2
8	MT22-1179	Oil Seal	4	26	MT22-1246	Cap, Automatic Slack Adj., L.H.	1
9	191758	Grease Fitting, 1/8	2		MT22-1247	Cap, Automatic Slack Adj., R.H.	1
10	MT22-1181	Spanner Housing Assy., L.H. <b>(Includes Items #7, 8 and 9)</b>	1		11500773	Bolt, M8 X 16 - 1.25	2
	MT22-1182	Spanner Housing Assy., R.H. <b>(Includes Items #7, 8 and 9)</b>	1		11503950	Bolt, M6 X 20 - 1.00	2
11	MT22-1183	Hex Bolt Special	8	27	MT22-1242	Roller Spring (Optional)	4
12	MT14-1142	Washer, Special	2		28	MT22-1251	Brake Spring and Roller Kit (MT22N/H Only) <b>(Includes Items #2, 3, 5, 6, 27)</b>
13	MT22-1197	Cam Shaft, L.H. (MT22N/H Only)	1				
	MT22-1198	Cam Shaft, R.H. (MT22N/H Only)	1				
	MT22-1174	Brake Spanner, L.H. (MT22/R Only)	1				
	MT22-1175	Brake Spanner, R.H. (MT22/R Only) (Not Shown)	1			AR = As Required	
14	MT22-1201	Spacer (MT22N/H Only)	2				
	MT22-1184	Spacer	2				
15	MT22-1199	Shim, .50 MM (MT22N/H Only)	AR				
	MT14-1144	Shim, .50 MM	AR				
16	MT22-1237	Automatic Slack Adj., L.H. (MT22N/H Only)	1				
	MT22-1238	Automatic Slack Adj., R.H. (MT22N/H Only)	1				
	MT22-1203	Slack Adjuster, L.H. (MT22/R Only)	1				
	MT22-1204	Slack Adjuster, R.H. (MT22/R Only)	1				

# TIE-ROD MT22/R/N/H

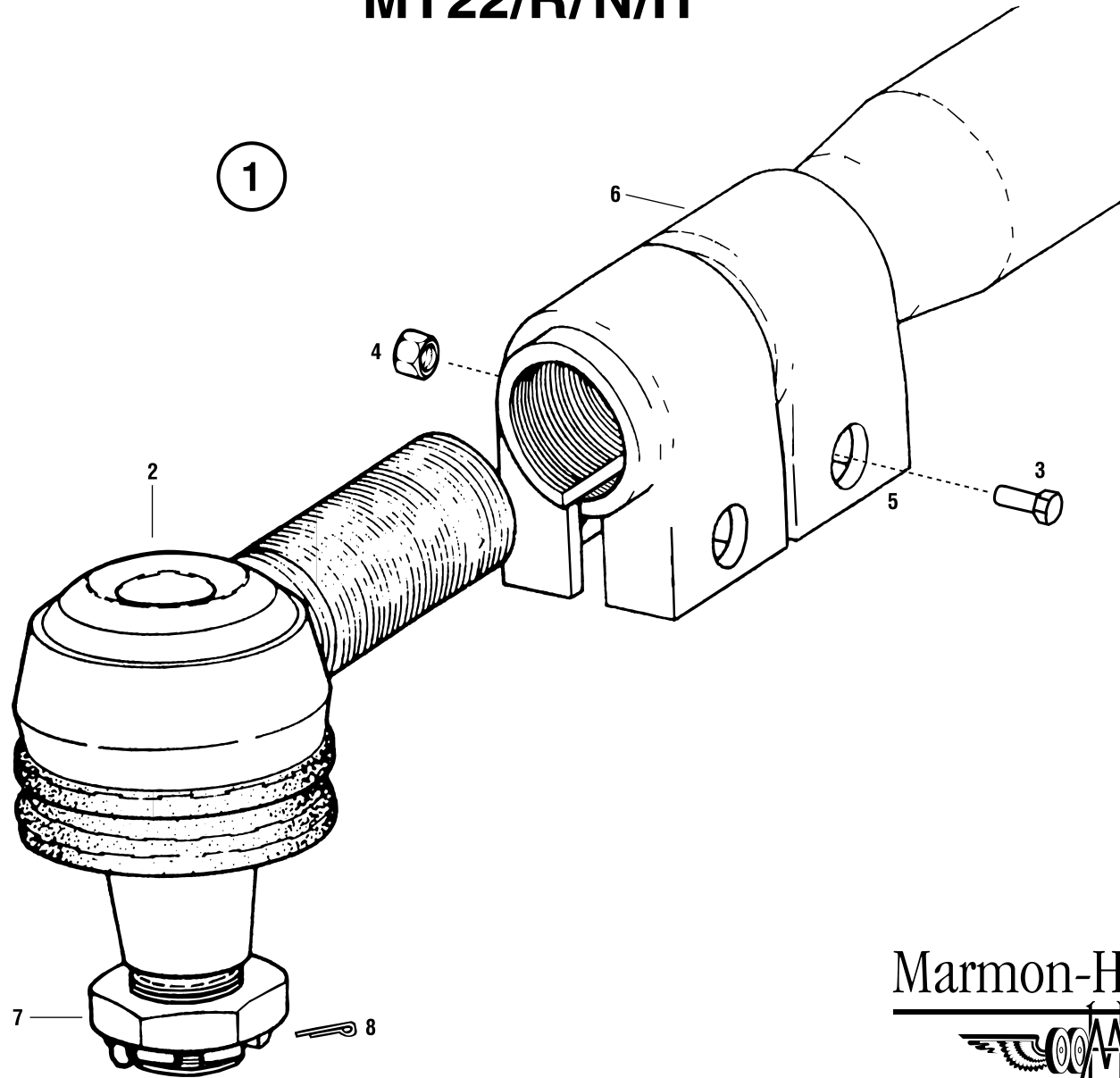

Marmon-Herrington  



# Marmon-Herrington



13001 Magisterial Drive • Louisville, KY 40223  
(502) 253-0277 • (800) 227-0727 • Fax (502) 253-0317  
E-mail: [info@marmon-herrington.com](mailto:info@marmon-herrington.com)



**Driving power since 1931.**

**Marmon-Herrington**



**13001 Magisterial Drive**

**Louisville, KY 40223**

**1-800-227-0727**

**[www.marmon-herrington.com](http://www.marmon-herrington.com)**