

T-SERIESTM

905L/905/910
AIR SUSPENSION SEATS

(OPTIONAL) AIR LUMBAR, HEADREST, 905 PASSENGER SWIVEL, 910 DRIVER SWIVEL,
SC-SELF CONTAINED 12v COMPRESSOR, 910SC DRIVER SWIVEL, 910SC HI-PROFILE
OPERATION AND SERVICE PARTS MANUAL

This seat conforms to
FMVSS 207 and 302 in effect
at time of manufacture

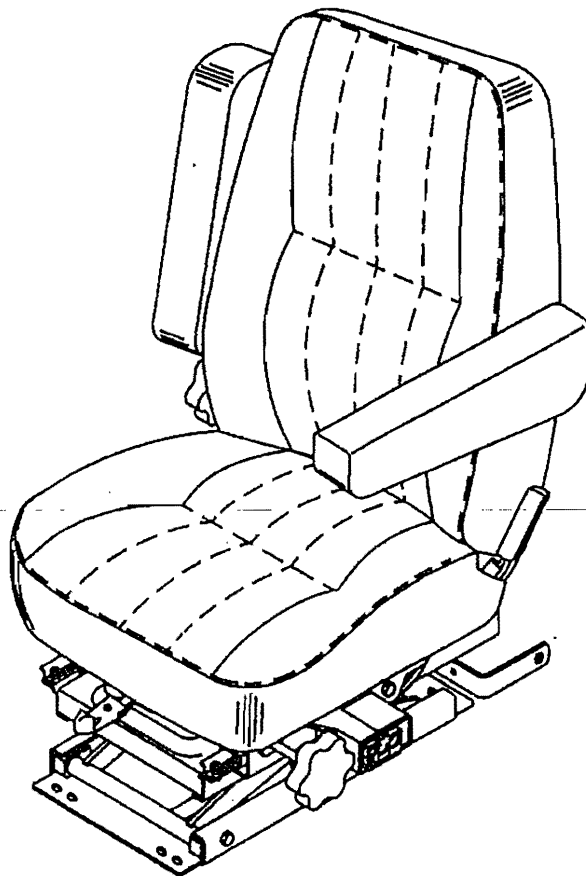
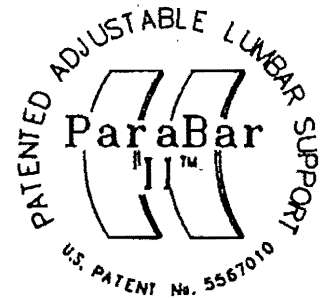

Seat Shown with Mid Height
Back and Optional Armrests

CATALOG NO.
1201694-002

©1998 BOSTROM SEATING INC.
REV E - 3/2003

OPERATION WARNING

WARNING

SERIOUS INJURY MAY OCCUR IF HEAD CLEARANCE IS NOT ADEQUATE. BEFORE DRIVING OR RIDING IN VEHICLE, ENSURE THAT THERE IS ADEQUATE HEAD CLEARANCE AT MAXIMUM UPWARD TRAVEL OF SEAT. SEE OPERATION MANUAL.

To check for adequate head clearance, sit in the seat and slowly raise it to its maximum upward position (see Comfort Adjustments).

SEAT BELTS SHOULD BE WORN AT ALL TIMES WHEN OPERATING THE VEHICLE.

Federal Motor Vehicle Safety Standard

This seat conforms to Federal Motor Vehicle Safety Standards (FMVSS) 207 and 302 in effect on the date of manufacture.

It is the responsibility of the installer to ensure that proper seat fastening hardware and seat belt anchorages (seat belt and tether belt system) are used in accordance with FMVSS 209 and 210.

To achieve compliance with FMVSS 207, use only high strength fasteners and heavy duty washers when installing seat assembly.

Bostrom
SEATING

Vigo Road
P.O. Box 566
Piedmont, AL 36272
(256) 447-9051
www.bostromseating.com

COMFORT ADJUSTMENTS

After installation the following comfort adjustments can be made to ensure the best performance.

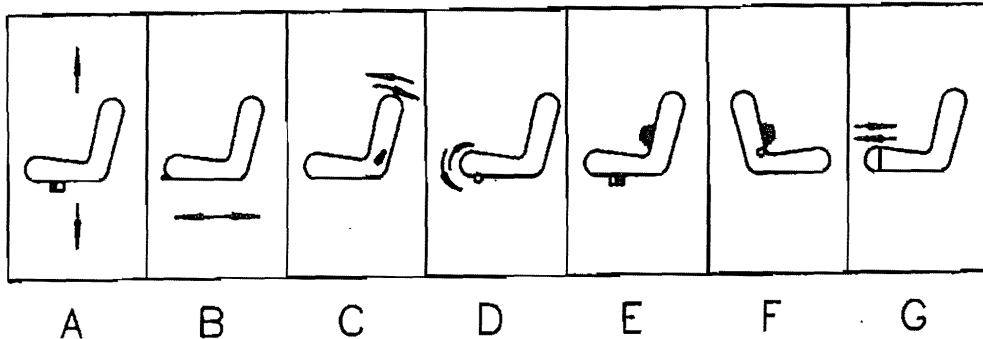

F - LUMBAR ADJUSTMENT
Rotate knob forward to increase or rearward to decrease the support in the lumbar area.

C - BACK ANGLE ADJUSTMENT
Lean forward slightly to remove pressure from seat back, hold handle rearward to adjust to any position within range.

G - THIGH EXTENSION ADJUSTMENT
Depress tab and pull out on thigh extension to unlock. Release tab and adjust by pulling out or by pushing in.

E - OPTIONAL AIR LUMBAR ADJUSTMENT (UPPER AND LOWER)
To increase lumbar support press control valve forward. To decrease lumbar support press control valve rearward.

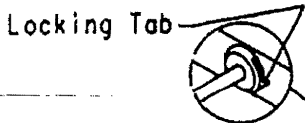

Locking Tab

B - FORE AND AFT SEAT POSITION ADJUSTMENT/OR FORE AND AFT ISOLATION
Hold lever to left to adjust seat position forward or backward. Isolation is provided when lever is in center (straight forward) position. To lock out, move lever to right.

D - SEAT CUSHION TILT ADJUSTMENT
Rotate seat tilt knob to decrease or increase seat tilt.

A - WEIGHT AND HEIGHT ADJUSTMENT
To raise seat, push the air valve lever upwards. To lower seat, push the air valve lever downwards. When adjusted properly and under normal driving conditions. The seat should not top nor bottom against the end limits of the vertical travel. Adjusted height position should aid drivers visibility and vehicle control.

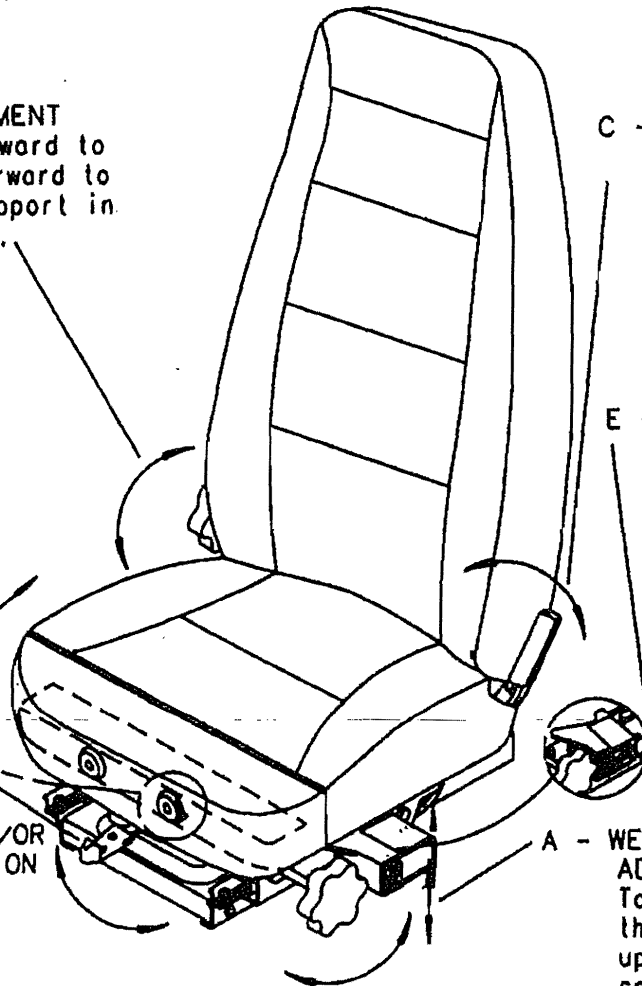

BOSTROM T-SERIES SEAT SWIVEL OPERATION

WARNING THE SWIVEL FEATURE OF THIS SEAT IS INTENDED SOLELY FOR OPERATION WHEN THE VEHICLE IS NOT IN MOTION. WHEN THE VEHICLE IS MOVING, THE SEAT MUST BE LOCKED IN THE FORWARD FACING POSITION AND THE SEAT BELT WORN FOR MAXIMUM OCCUPANT SAFETY

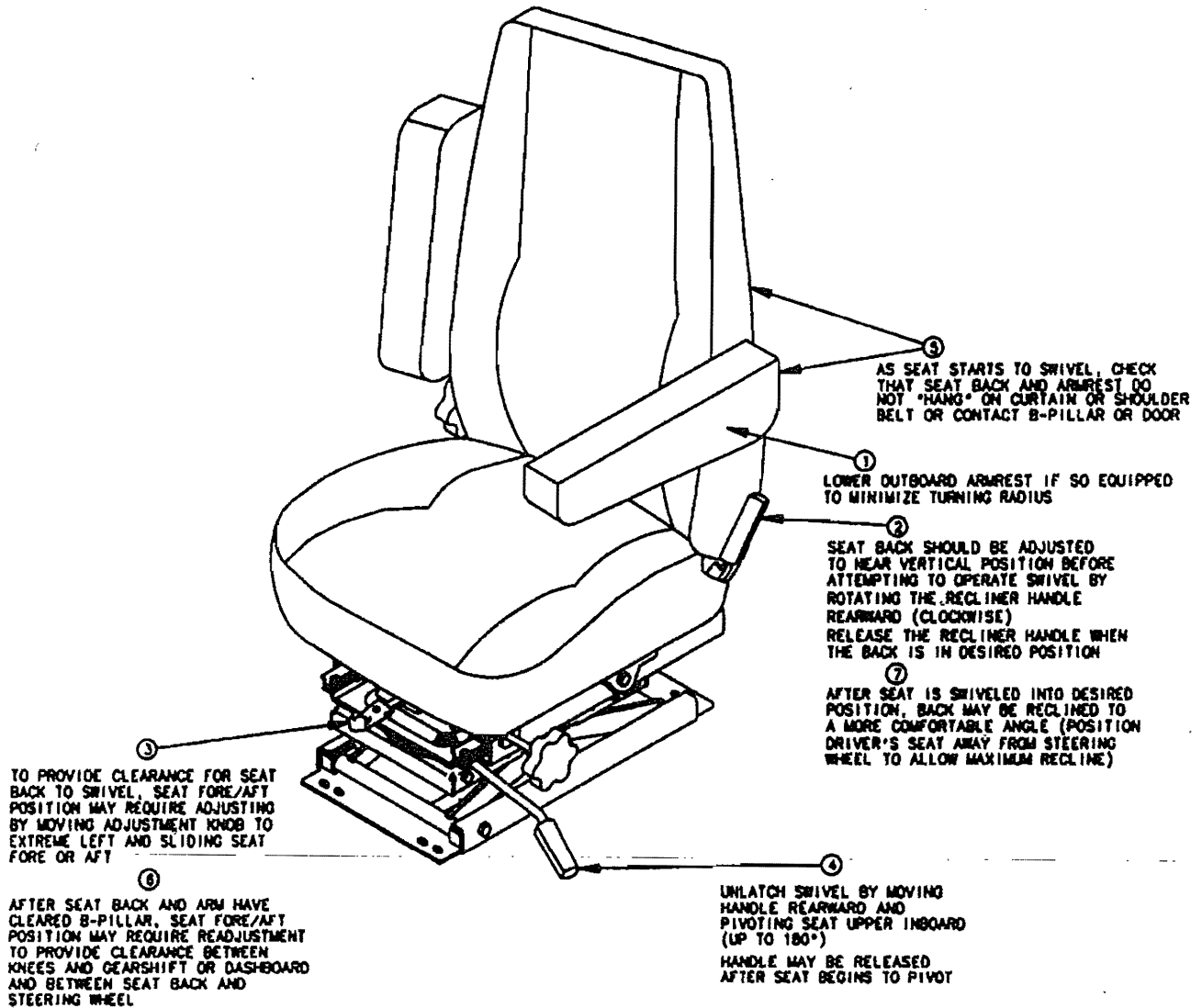

SWIVEL OPERATION SEQUENCE SUMMARY

(SEE DETAILS ABOVE)

- ① OUTBOARD ARMREST DOWN
- ② BACK NEAR VERTICAL POSITION
- ③ ADJUST FORE/AFT AS REQUIRED
- ④ UNLATCH SWIVEL LATCH AND PIVOT
- ⑤ CHECK ARM AND BACK CLEARANCE
- ⑥⑦ READJUST SEAT AND BACK AS DESIRED

ILLUSTRATED PARTS BREAKDOWN

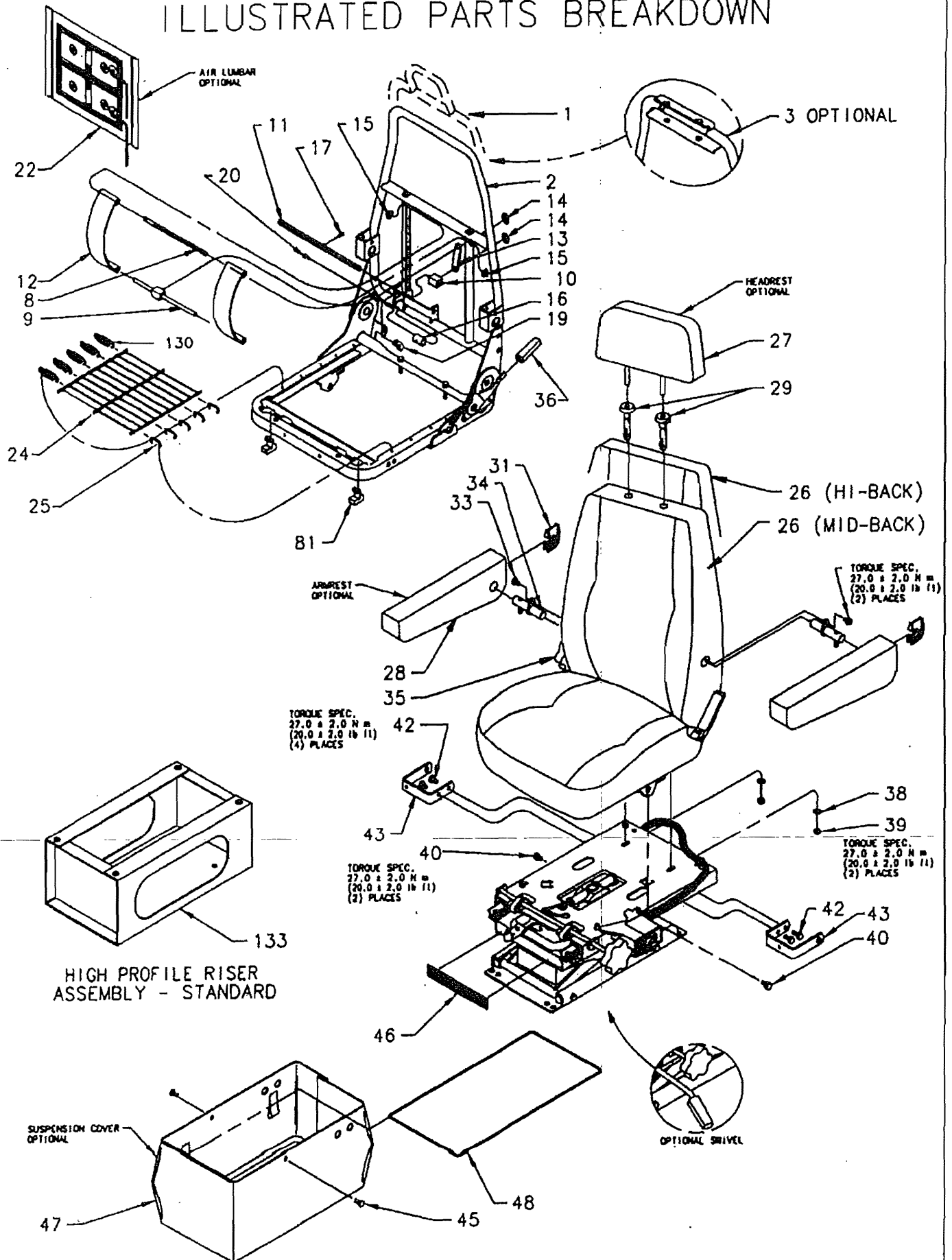

ILLUSTRATED PARTS BREAKDOWN

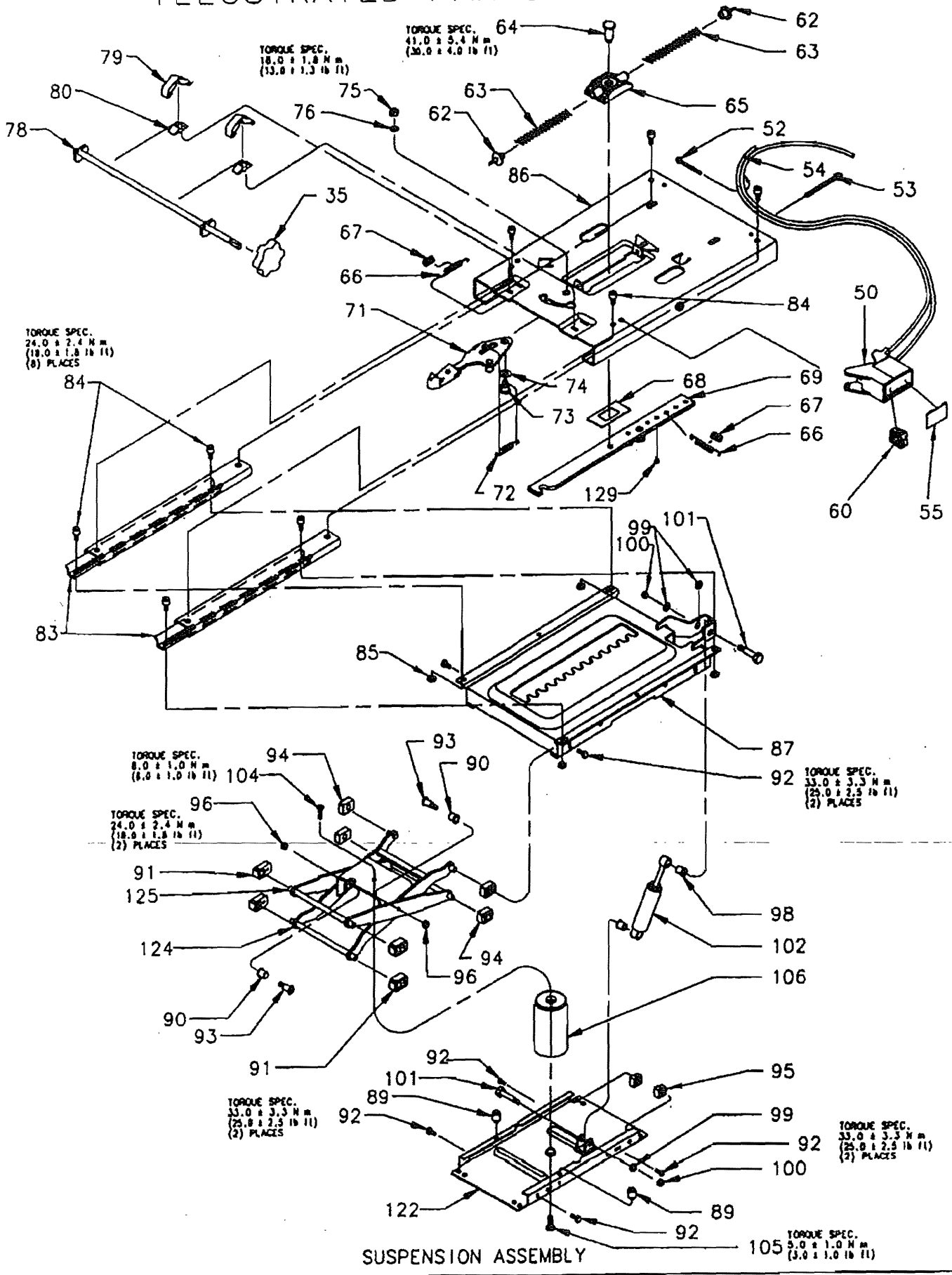

SUSPENSION ASSEMBLY

ILLUSTRATED PARTS BREAKDOWN

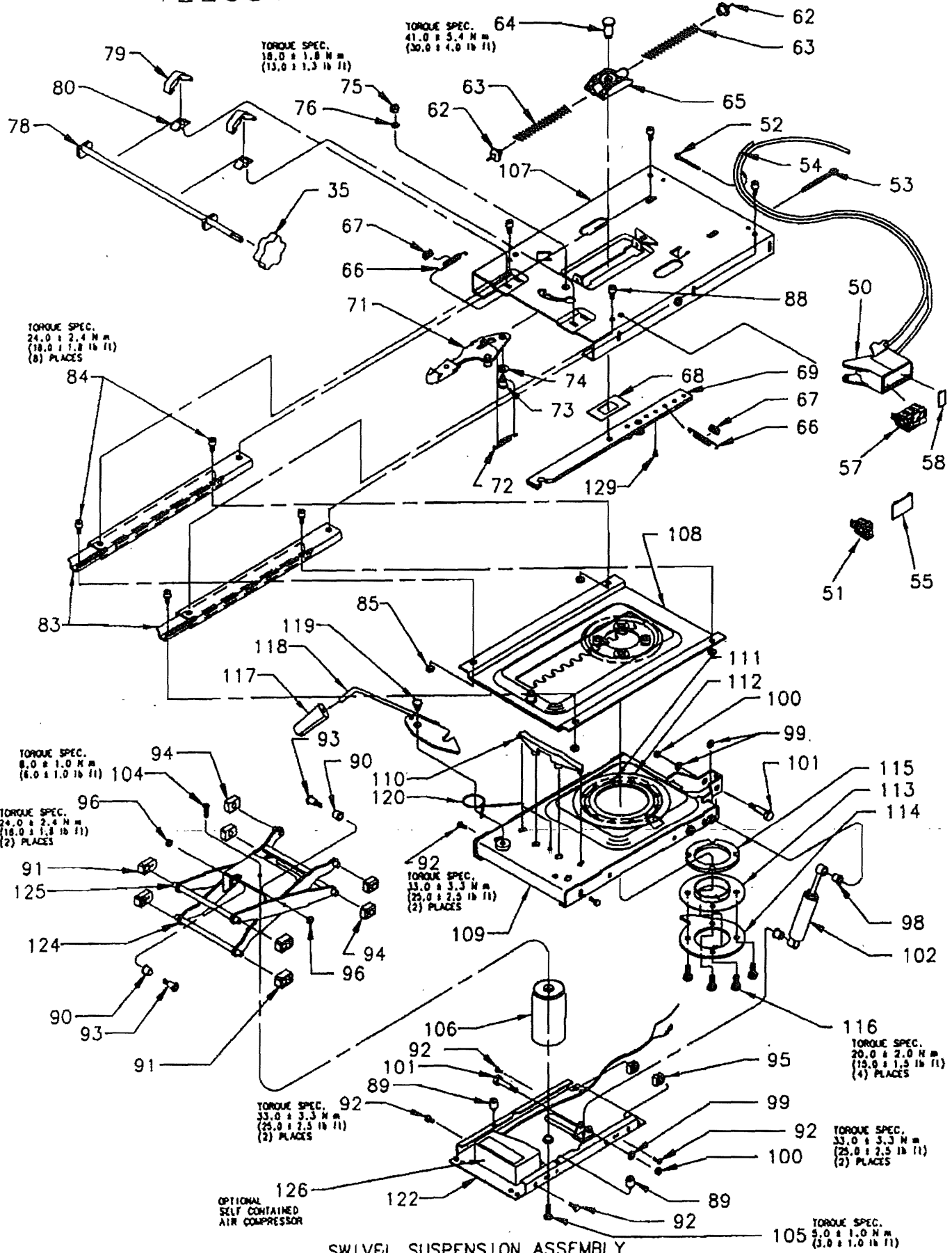

SWIVEL SUSPENSION ASSEMBLY

PARTS REPLACEMENT LIST LOW PROFILE SUSPENSION SEAT

ORDERING INSTRUCTIONS: Order by Part Number, NOT Reference Number.

HOW TO USE: Find the corresponding part that you wish to replace on the exploded view illustration and note its reference number. Refer to list below and record part number, quantity required and description. Order cover pad kits or armrests by color and material.

ORDER FROM: Your truck dealer or Bostrom Authorized Distributor for your area.

REF NO	PART NO	DESCRIPTION	QTY	REF NO	PART NO	DESCRIPTION	QTY
1	6200906-001	Frame Assy - High Back		29	6201133-001	Grommet	2
2	6200908-001	Frame Assy - Mid Back		30	6222159-001	Armrest Insert Kit, Includes Item 31	
3	6201118-001	Frame Assy - w /Headrest		31	*	Insert	
4	6201316-001	Frame Assy - w /Headrest Air Lumbar (Not Shown)		32	6222160-001	Armrest Bracket Kit, Includes Items 31,33,34	
5	6201023-001	Frame Assy - Mid Back w /Air Lumbar (Not Shown)		33	*	Screw 5/16"x1/2" Hex Tap	1
6	6201025-001	Frame Assy - High Back w /Air Lumbar (Not Shown)		34	*	Armrest Shaft	1
7	6222137-001	Para Bar II Lumbar Kit, Includes Items 8-17		35	6200413-002	Lumbar Knob / Seat Tilt Knob	1
8	*	Lumbar Supt. Shaft	1	36	6201619-001	Recliner Handle	1
9	*	Lumbar Slide Shaft	1	37	6222007-001	Kit Fastener Mounting Includes Items 38-40	
10	*	Lumbar Adj.Block	1	38	*	Washer Flat	2
11	*	Lumbar Adj.Shaft	1	39	*	Nut M8x1.25	2
12	*	Lumbar Spring	2	40	*	Shoulder Bolt M8	2
13	*	Lumbar Linkage	1	41	6222005-001	ICP Bracket Kit, Includes Items 42,43	
14	*	Push Nut 3/8"	2	42	*	Screw Cap M8x12MM	4
15	*	Push Nut 5/16"	2	43	*	ICP Bracket	2
16	*	Spacer	1	44	**	Suspension Cover Kit Includes Items 45-48	
17	*	Roll Pin	1	45	*	Fastener	2
18	6107030-001	Back Restriction Kit , Includes Items 19,20		46	*	Velcro	1
19	*	Stop Block	1	47	*	Suspension Cover	1
20	*	Screw 10-32	1	48	*	Wire	1
21	6222141-001	Lumbar Kit (Air Lumbar) Includes Item 22		49	6222207-001	Air Valve (Height Control) Includes Items 50-55	
22	*	Lumbar Bladder	1	50	*	Valve Mounting Pod	1
23	6222202-001	Foam Support Kit, Includes Items 24,25 and 130		51	*	Air Valve (Height Control)	1
24	*	Flex-o-lator Support (Grid)	1	52	*	Wire Tie 3"	3
25	*	Flex-o-lator Clip	5	53	*	Wire Tie 6"	1
26	**	Upper or Cover Pad Kit		54	*	Air Line 1/4"O.D	7.5LF
27	**	Headrest Assy.		55	***	Plug - No longer used	1
28	**	Armrest Assy.					

PARTS REPLACEMENT LIST

LOW PROFILE SUSPENSION SEAT

CONTINUED

REF NO	PART NO	DESCRIPTION	QTY	REF NO	PART NO	DESCRIPTION	QTY
56	6222206-001L.H	Air Lumbar Valve Kit. L.H		86	6222168-004	Isolator Assy-Non-Swivel ,includes items 62-69 , 71-76 , 83-85 and 87	
	6222206-002R.H	Air Lumbar Valve Kit. R.H Not Shown.					
57	*	Air Valve Assembly , Height Control / Lumbar Valve	1	87	6201571-001	Upper Plate Weldment	1
58	**	Plug -No longer used	1	88	6222076-001	Suspension Hardware Kit, includes items 89-96	
59	6222208-001	Air Valve Kit (For SC Only) Height Control , includes items 50,52-55 and 60		89	*	Rubber Bumper	2
60	*	Height Control ,SC Air Valve	1	90	*	Bearing Multilube	2
61	6222133-001	Isolator Spring Kit , includes items 62-69	2	91	*	Bearing Block	4
62	*	Rubber Bumper	2	92	*	Screw Cap M8x20MM	6
63	*	Isolator Spring	2	93	*	Shoulder Bolt M8x1.25	2
64	*	Shoulder Bolt M10x1.50	1	94	*	Slide Block	4
65	*	Pivot Block Assy.	1	95	*	Stop Block Assy.	2
66	*	Latch Spring	2	96	*	Nut Hex M8x1.25LK	2
67	*	Split Poly Loom	2	97	6222078-001	Standard Damper Kit, includes items 98-102	
68	*	Spacer	1	98	*	Bearing Multilube	2
69	*	Latch Bar	1	99	*	Washer Flat	2
70	6222134-001	Control Handle Kit, includes items 71-76		100	*	Nut Hex M8x1.25LK	2
71	*	Control Handle Assy.	1	101	*	Shoulder Bolt M8x1.25	2
72	*	Spring Lockout	1	102	*	Standard Damper	1
73	*	Hex Head - Shoulder	1		6222079-001	Heavy Duty Damper Kit, (Optional)	
74	*	Belleville Washer	1	103	6222084-001	Air Spring Kit, includes items 104-106	
75	*	Nut Hex M8x1.25LK	1	104	*	Screw M8x1.25x25 FLHD C4.8	1
76	*	Washer	1	105	*	Screw FLHD M8	1
77	6222135-001	Seat Tilt Replacement includes items 35, 78-81		106	*	Air Spring Assy.	1
78	*	Tilt Rod Weldment	1	107	6222168-007	Isolator Assy. Passenger Swivel includes items 62-69,71-76,83-85, and 108-120	
79	*	Upper Tilt Bracket	2	108	*	Weldment Swivel Plate	1
80	*	Lower Tilt Bracket	2	109	*	Upper Plate	1
81	*	Slide Block-Long	2	110	*	Strike Plate	1
82	6222165-001	Slide Rail Kit, includes items 83-85		111	*	Ball Spherical	12
83	*	Slide Rail	2	112	*	Guide Plate	1
84	*	Screw Socket HD M8x12MM	8	113	*	Swivel Spacer	1
85	*	Nut Hex M8	4	114	*	Swivel Mount	1

**PARTS REPLACEMENT LIST
LOW PROFILE SUSPENSION SEAT
CONTINUED**

REF NO	PART NO	DESCRIPTION	QTY	REF NO	PART NO	DESCRIPTION	QTY
115	*	Torque Plate	1	123	6222112-001	Lever Assy. Includes Items 90,93,96,124 and 125	
116	*	Screw Cap M8x20MM	4	124	*	Inner Lever Weldment	1
117	*	Swivel Handle	1	125	*	Outer Lever Weldment	1
118	*	Swivel Pawl Assy.	1	126	6222035-001	Compressor Kit SC Only	
119	*	Shoulder Bolt	1	128	6201114-001	Fore / Aft Adj. Restriction Kit, Includes Item 129	
120	*	Spring Torsion	1	129	*	Restrictor Screw	1
121	6222148-001	Swivel Kit, Includes Items 111-116		130	*	Flex-o-lator spring	5
	6222168-008	Isolator Assy. Driver Swivel (Not Shown)		133	6222152-001	High Profile Riser Assy.	
122	6201073-001	Lower Base Assy.	1				

NOTE: AIR LUMBAR NOT AVAILABLE ON SC SEATS.

* EXCEPT AS NOTED, KITS CONTAIN ALL ITEMS DENOTED BY ASTERISK LISTED BELOW EACH KIT PART NUMBER.

** SEE YOUR DEALER OR BOSTROM AUTHORIZED DISTRIBUTOR FOR UPPER, ARMREST, SUSPENSION COVER KIT OR COVER PAD KIT PART NUMBERS APPROPRIATE FOR YOUR SEAT.

*** ITEM NO LONGER AVAILABLE.

REMOVAL / REASSEMBLY

Suspension Rebuild Bearing/Slide Block Replacement

1. Bleed all air from supply line. Disconnect air supply line to seat. Using air valve, exhaust all air from air spring. Remove complete seat assembly from vehicle.
2. Remove seat/back assembly (26) from suspension per procedures shown.
3. If seat assembly has a suspension cover (47), remove along with fasteners (45), after removing ICP bracket (43) and cap screws (42).
4. Block suspension up with a spacer placed between lower base assy. (122) and the upper frame (87).
5. Disconnect air line (54) from air spring assembly (106) by pushing in on collar of fitting while pulling air line (54) out of fitting.
6. Remove top and bottom screw from air spring (104) and (105) remove air spring assembly from suspension assembly.
7. Remove damper assembly (102) by removing shoulder bolts (101), nuts (100) and washers (99) (see procedure for damper replacement).
8. Remove cap screws (92) from upper front bearing blocks (91) and screws (92) from lower rear stop blocks .
9. Remove isolator assembly (86) by lifting and sliding it forward until bearing blocks (91) can be removed from cutouts in channels on upper frame (97). Then slide channel rearward until slide blocks (94) can be removed. **Be careful not to pinch fingers in lever assembly.**
10. Remove cap screws (92) from lower front bearing blocks (91) and slide lever assemblies (124 and 125) forward until bearing blocks (91) are removed from channel on base (122). Then slide lever assemblies rearward until slide blocks (94) are removed from channel. **Be careful not to pinch fingers in lever assemblies.**
11. Remove shoulder bolts (93) and nuts (96) from pivots of lever assemblies (124 and 125) and inspect bearings (90) Replace if worn.
12. Replace bearings (90) at pivots on lever assembly (124) by pushing the old out and pressing in new. Flange of bearings (90) should be on outside of lever assembly (124).
13. Reassemble reverse order. Torque pivot shoulder bolts (93) to 18.0 +/- 1.8 ft. lbs.
14. Install bearing blocks (91) and slide blocks (94) on levers with beveled surfaces outward and slide levers with blocks into channel on lower base assy. (122). Torque screws (92) to 25.0 +/- 2.5 ft. lbs.
15. After installing bearing blocks (91) and slide blocks (94) on levers, slide isolator assembly (86) over blocks. Line up screws (92) with bearing blocks (91) . Torque screws (92) to 25.0 +/- 2.5 ft.-lbs.
16. Manually move suspension up and down to make sure there are no clearance problems. **Be careful not to pinch fingers in linkage.**
17. Block up suspension and reinstall air spring assembly (106). Torque upper screw (104) to 6.0 +/- 1.0 ft.-lbs. and lower screw (99) to 3.0 +/- 1.0 ft.-lbs. (see procedure shown for air spring reassembly).
18. Reinstall damper assembly (102) with washer (99) and nuts (100) (see procedure for damper replacement).
19. Reinstall suspension cover (47) and ICP brackets (43) if removed (see step #3).
20. Install seat / back assembly (26)

Seat/Back Assembly (26) Removal/Reassembly

1. Adjust the seat upper to most rearward position and remove two nuts (39) and flat washers (38) from underside of channel assembly (86).
2. Remove two shoulder bolts (40) from channel assembly (86).
3. Reverse procedure to reassemble.

Air Spring Assembly (106) Removal/Reassembly

Remove complete seat assembly from vehicle.

1. Fill air spring assembly (106) so that seat is at maximum height (see comfort adjustments).

REMOVAL / REASSEMBLY

2. Block suspension up with a spacer placed between the lower base (122) and the upper base (87).
3. Release air pressure from air spring so that seat is supported by spacer (see comfort adjustments).
4. Disconnect air line (54) from air spring assembly (106) by loosening air fitting and pulling air line out of fitting.
5. Remove top screw (104) and bottom screw (105) from air spring (106) and remove air spring assembly from suspension assembly.
6. Position air spring so that fitting at bottom of air spring (100) is toward the rear of the seat. Install top screw (104) Torque to 6.0 +/- 1.0 ft. lbs.
7. Install bottom screw (105) Torque to 3.0 +/- 1.0 ft.-lbs.
8. Reconnect air line (54) to fitting in air spring assembly (106) by pushing air line into fitting.
9. Fill air spring assembly (106) (see comfort adjustment) and remove spacer block.
5. Install new screws (84) and nuts (85).
6. Reassemble seat/back assembly (26).

Damper Replacement (102)

Seat need not be removed from truck.

1. Be sure suspension is at maximum height. Add air if needed (see comfort adjustment).
2. Move Isolator assembly (86) to full frontward position to gain working room.
3. Remove shoulder bolts (101) and hex nuts (100) and washers (99).
4. Remove damper assembly.
5. Install new damper with flanges of bearings to the outside of the suspension. Add washers (99) and install shoulder bolts (101) and hex nuts (100).

Slide Rail (83) Replacement

1. Remove seat/back assembly (26). NOTE: See Seat/Back Assembly Removal/Reassembly.
2. Once seat/back is removed, adjust Isolator assembly (86) to the rear. Remove front screws (84) and nuts (85). Carefully move Isolator assembly (86) to the front. Remove screws (84) and nuts (85).
3. Remove top screws (84).
4. Remove and install one slide rail (83) at a time.