

ITEM NO.	PART NUMBER	DESCRIPTION	QTY.
1	08816363C	SPL, 8 X 8, W/ 7/16 SWP	1
2	03300602A	HOSE, #8 RGT	1.167'
3	03300602A	HOSE, #8 RGT	3.5'
4	08816344C	8FO X 8SB 90 W/134 HCP	1
5	08816011C	FTG, 8FO X 8HS 90°	1
6	08813921A	SWH, HiPr, 7/16	1

**THE ORIENTATION OF THE FITTINGS ARE BASED ON THE WRITING ON THE HOSE BEING POSITIONED AT 0°**

1.) SPLICE FITTING 08816363C (ITEM 1) NEEDS TO BE POSITIONED AT 0°, AS SHOWN.

2.) FITTING 08816344C (ITEM 4) NEEDS TO BE POSITIONED AT 180°, AS SHOWN.

3.) FITTING 08816011C (ITEM 5) NEEDS TO BE POSITIONED AT 180°, AS SHOWN.

4.) SWITCH 08813921A (ITEM 6) IS ATTACHED TO SPLICE FITTING (ITEM 1) AS SHOWN.

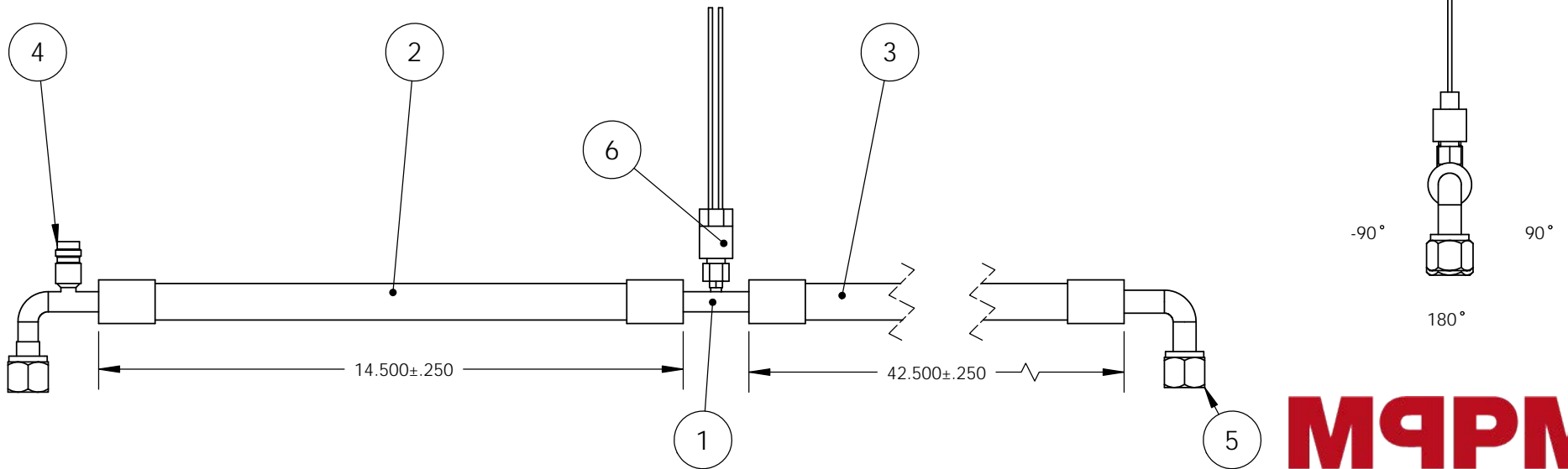

**MPPM**  
Mixer & Plant Parts Mfg

NOTE:

1) ALL DIMENSIONS TO OUTSIDE UNLESS OTHERWISE SPECIFIED.

UNLESS OTHERWISE SPECIFIED:

.XX +OR- .030  
.XXX +OR- .015  
HOLE DIA. +.015 -.000

INTERPRET GEOMETRIC TOLERANCING PER:

MATERIAL

---

FINISH

---

DO NOT SCALE DRAWING

	NAME	
DRAWN	DWB	
REDRAWN BY		
CHECKED BY		
ENG APPR.		
Q.A.		

COMMENTS:

TITLE:

ASY, HS, 6344 X  
6363 X 6011

SIZE	DWG. NO.	REV
<b>A</b>	Terex 23630	

SCALE: 1:4 | WEIGHT: | SHEET 1 OF 1

5

4

3

2

1